

Image Reconstruction

Parallel Imaging II

M229 Advanced Topics in MRI

Kyung Sung, Ph.D.

2020.05.26

Class Business

- Final project abstract / presentation
 - Abstract due on 6/5 by 5pm
 - Presentation file due on 6/11 by 5pm
- Office hours
 - Instructors: Fri 10-12 noon
 - email beforehand would be helpful

Today's Topics

- Parallel Imaging
 - SMASH review
 - Auto-SMASH
 - GRAPPA

SMASH Review

- Signal Equation:

$$\hat{m}_j(k_x, k_y) = \int_y \int_x C_j(x, y) m(x, y) \exp^{-i2\pi(k_x \cdot x + k_y \cdot y)} dx dy$$

$m(x, y)$ = image

$C_j(x, y)$ = j^{th} coil sensitivity

$$\hat{m}_j(k_y) = \int_y C_j(y) m(y) \exp^{-i2\pi(k_y \cdot y)} dy$$

SMASH Review

- The linear combination of coil sensitivities looks like sinusoids:

$$e^{-i2\pi(m\Delta k_y)y} = \sum_{j=0}^{L-1} a_{j,m} C_j(y)$$

- Once we have $a_{j,m}$,

$$\hat{m}(k_y + m\Delta k_y) = \int_y m(y) e^{-i2\pi k_y y} e^{-2\pi(m\Delta k_y)y} dy$$

$$\hat{m}(k_y + m\Delta k_y) = \int_y m(y) e^{-i2\pi k_y y} \sum_{j=0}^{L-1} a_{j,m} C_j(y) dy$$

SMASH Review

$$\hat{m}(k_y + m\Delta k_y) = \int_y m(y) e^{-i2\pi k_y y} \sum_{j=0}^{L-1} a_{j,m} C_j(y) dy$$

$$\hat{m}(k_y + m\Delta k_y) = \sum_{j=0}^{L-1} a_{j,m} \int_y C_j(y) m(y) e^{-i2\pi k_y y} dy$$

$$\hat{m}(k_y + m\Delta k_y) = \sum_{j=0}^{L-1} a_{j,m} m_j(k_y)$$

To the board ...

SMASH Reconstruction

$$S(k_x, k_y) = \text{FT}[\rho(x, y) * C_1(x, y)]$$

$$\rho(x, y) * C_1(x, y)$$

$$S(k_x, k_y) = \text{FT}[\rho(x, y) * C_2(x, y)]$$

$$\rho(x, y) * C_2(x, y)$$

$$S(k_x, k_y) = \text{FT}[\rho(x, y) * C_3(x, y)]$$

$$\rho(x, y) * C_3(x, y)$$

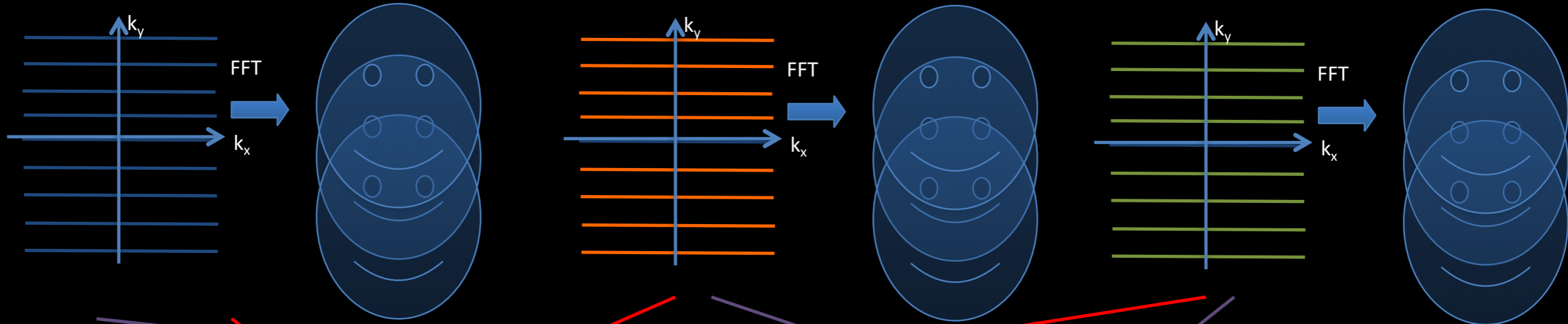

Combined with $h_1, h_2,$
& h_3 weightings

Combined with $n_1, n_2,$
& n_3 weightings

Zeroth Harmonic, $m=0$

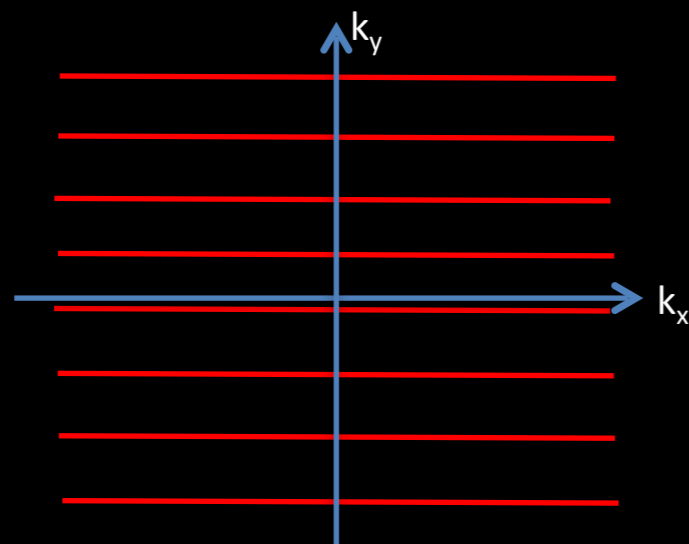

$$\hat{\rho}(k_x, k_y - m\Delta k_y)$$

First Harmonic, $m=1$

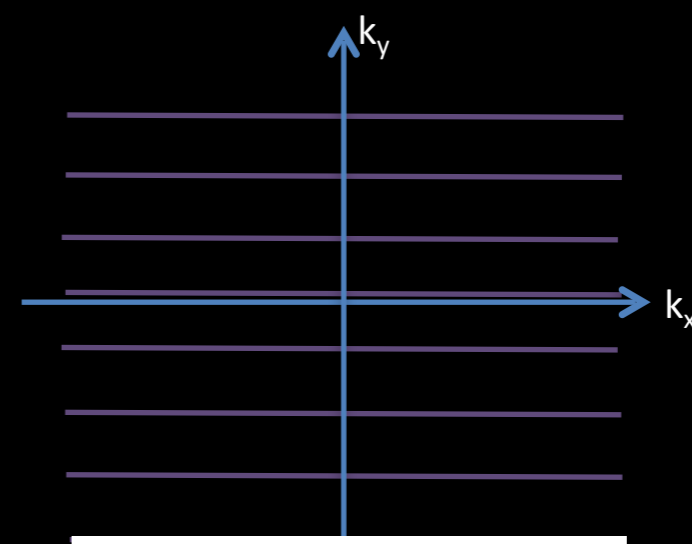

$$\hat{\rho}(k_x, k_y - m\Delta k_y)$$

Auto-SMASH

- Estimate $a_{j,m}$ directly

calibration

$$\hat{m}(k_y + m\Delta k_y) = \sum_{j=0}^{L-1} a_{j,m} m_j(k_y)$$

synthesis

- Solve for $a_{j,m}$ from calibration data & synthesize the missing data with $a_{j,m}$

Parallel Imaging (GRAPPA)

GRAPPA

- Coil sensitivities are
 - local in image space
 - extended in k-space

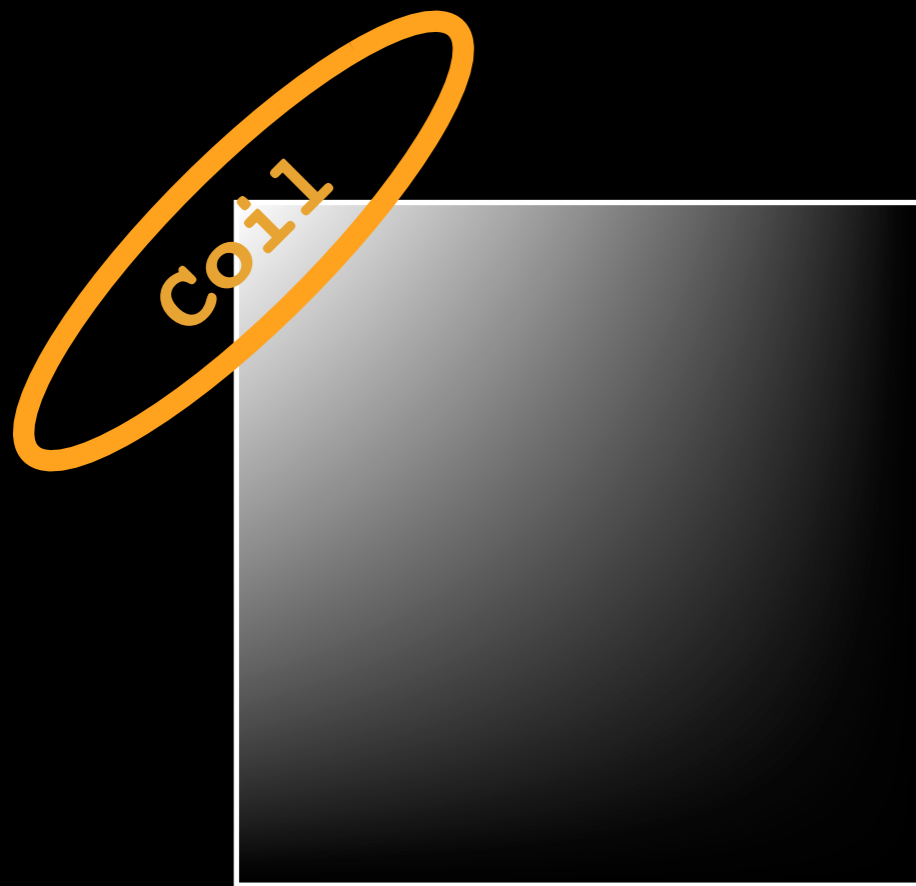

$$m(\vec{x})C_j(\vec{x})$$

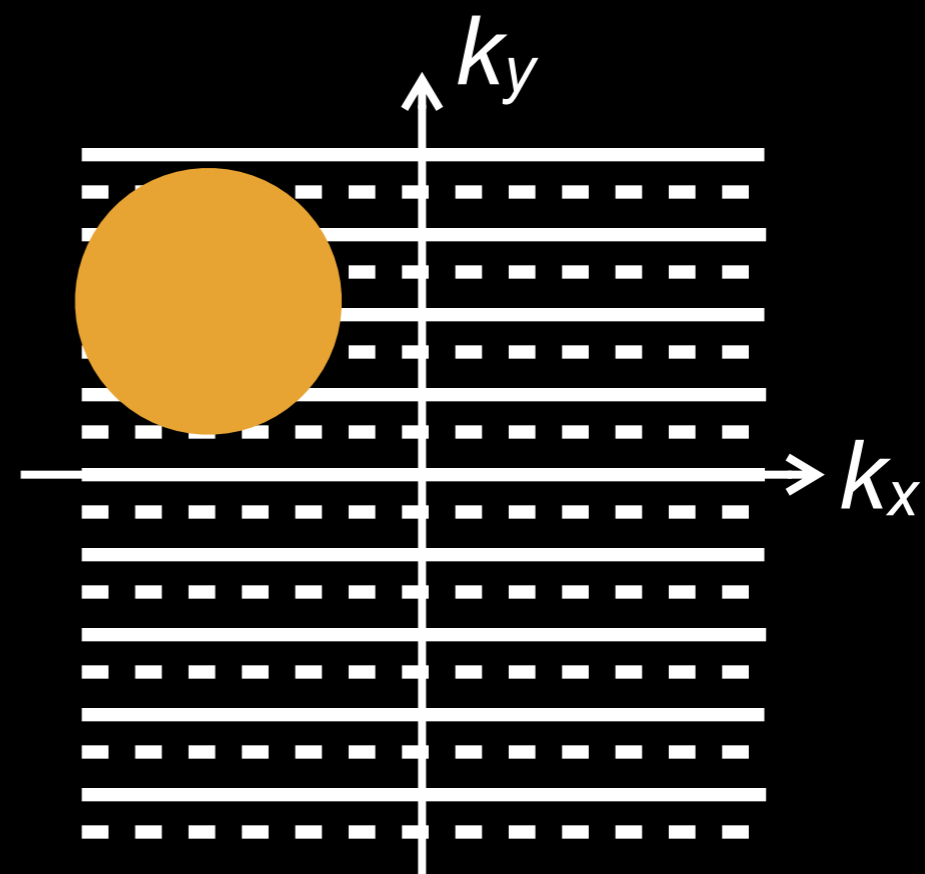

$$M(\vec{k}) * C_j(\vec{k})$$

GRAPPA

- Missing information is implicitly contained by adjacent data

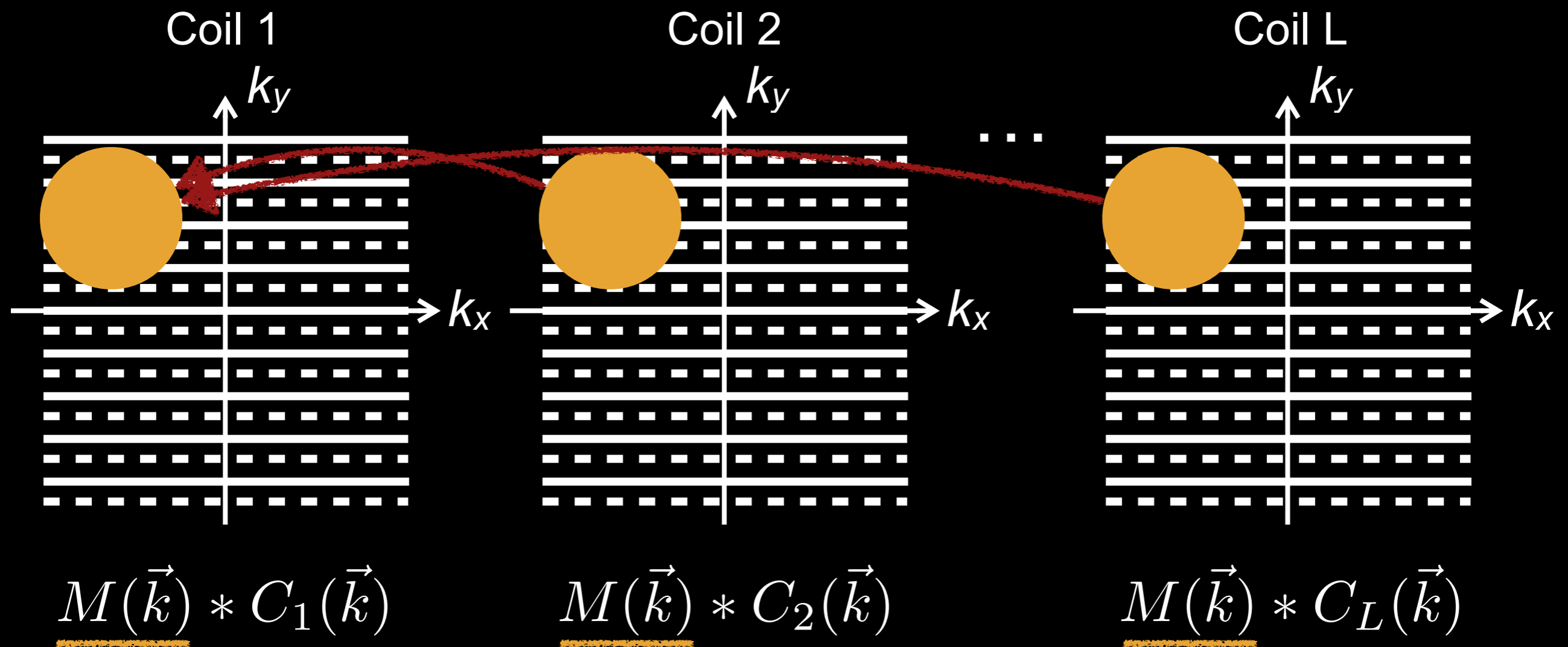

GRAPPA Reconstruction

- How do we find missing data from these samples?

$$\hat{m}_k(k_x, k_y) = \sum_{i,j,k} a_{i,j,k} \cdot m_k(k_x + i\Delta k_x, k_y + j\Delta k_y)$$

missing data
for each coil

weights

neighborhood data
for each coil

Auto-Calibration

$$\hat{m}_k(k_x, k_y) = \sum_{i,j,k} a_{i,j,k} \cdot m_k(k_x + i\Delta k_x, k_y + j\Delta k_y)$$

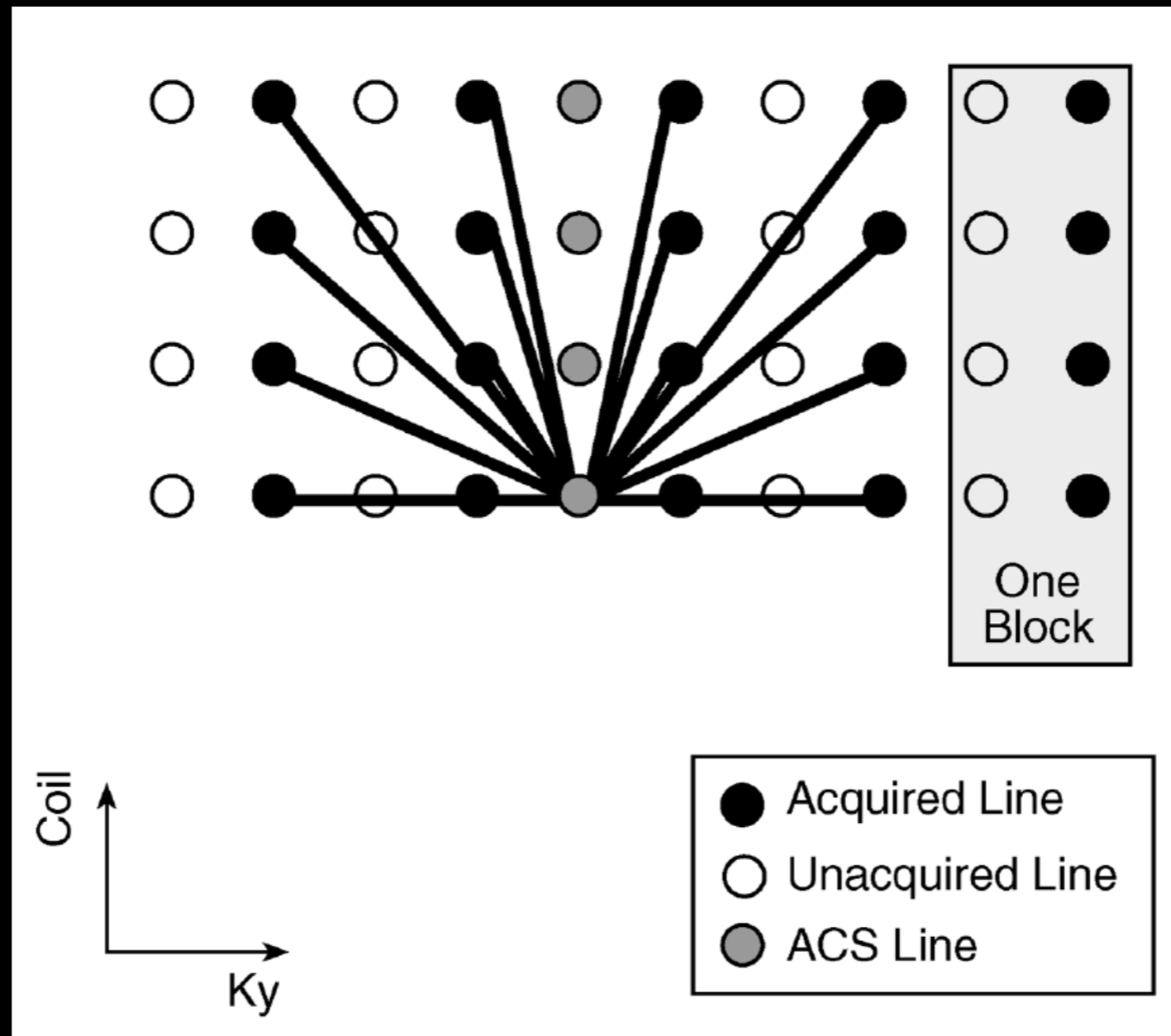

Auto-Calibration

- Assume there is a fully sampled region
- We have samples of what the GRAPPA synthesis equations should produce

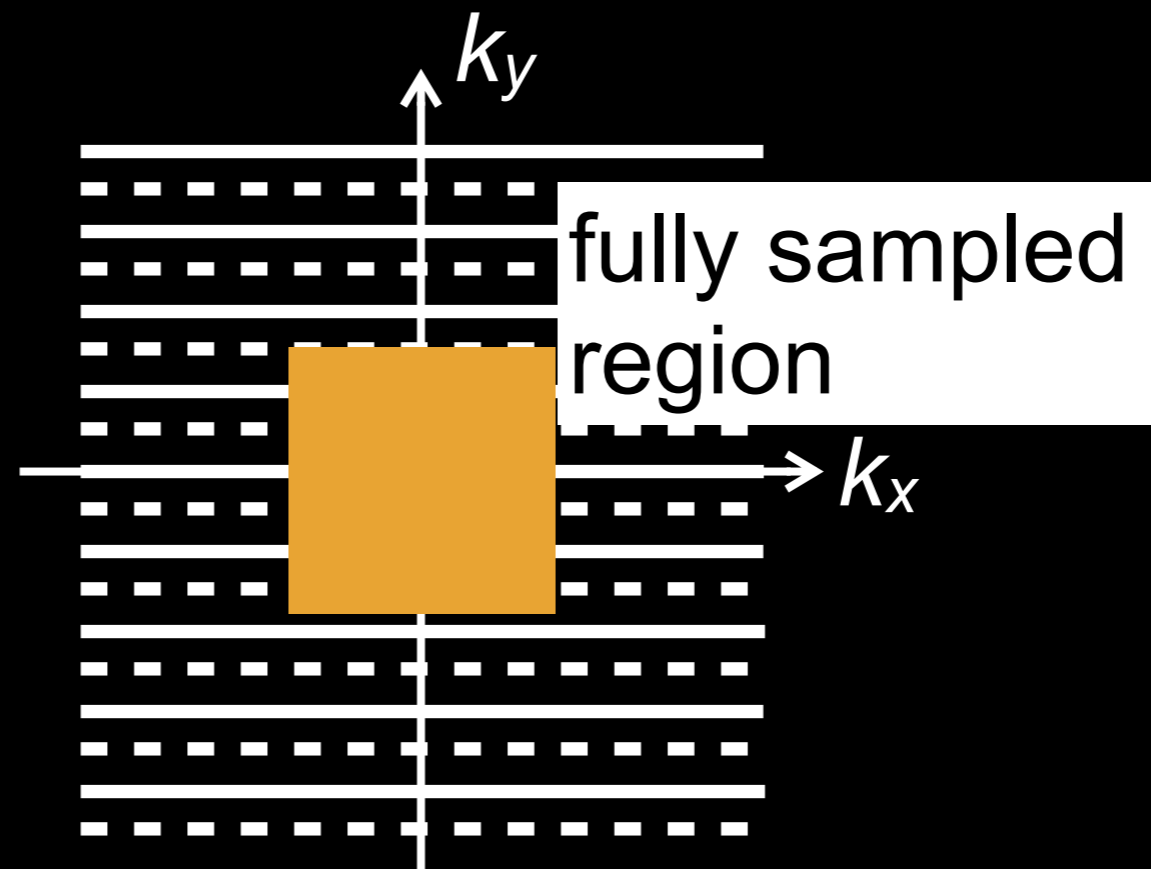

- Invert this to solve for GRAPPA weights

Auto-Calibration

- Calibration area has to be larger than the GRAPPA kernel
- Each shift of kernel gives another equation

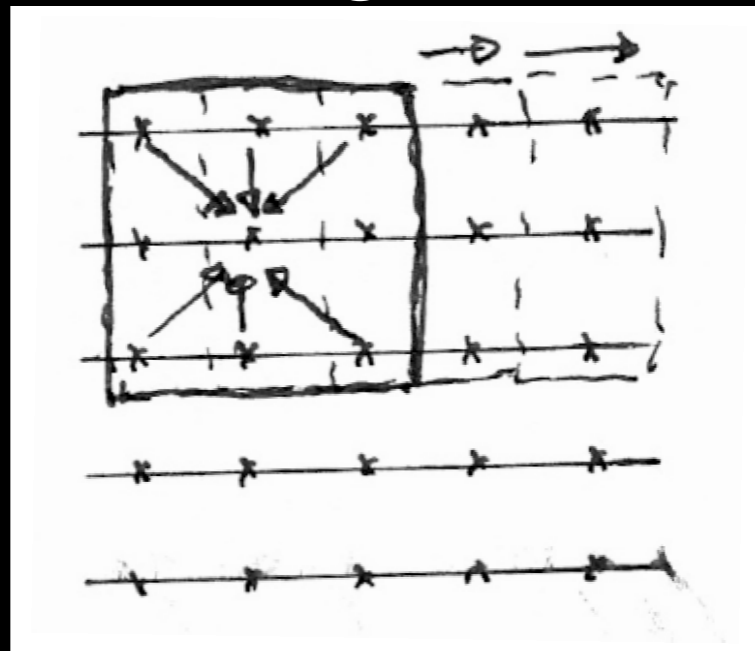

- Here, 3x3 kernel, 5x5 calibration area gives 9 equations

Auto-Calibration

$$\hat{m}_k(k_x, k_y) = \sum_{i,j,k} a_{i,j,k} \cdot m_k(k_x + i\Delta k_x, k_y + j\Delta k_y)$$

- Write as a matrix equation

GRAPPA

Coefficients

$$M_{k,c} = M_A \cdot a_k$$

Calibration

Neighborhood

Data

Data

- GRAPPA weights are:

$$a_k = (M_A^* M_A + \lambda I)^{-1} M_A^* M_{k,c}$$

GRAPPA - Synthesis

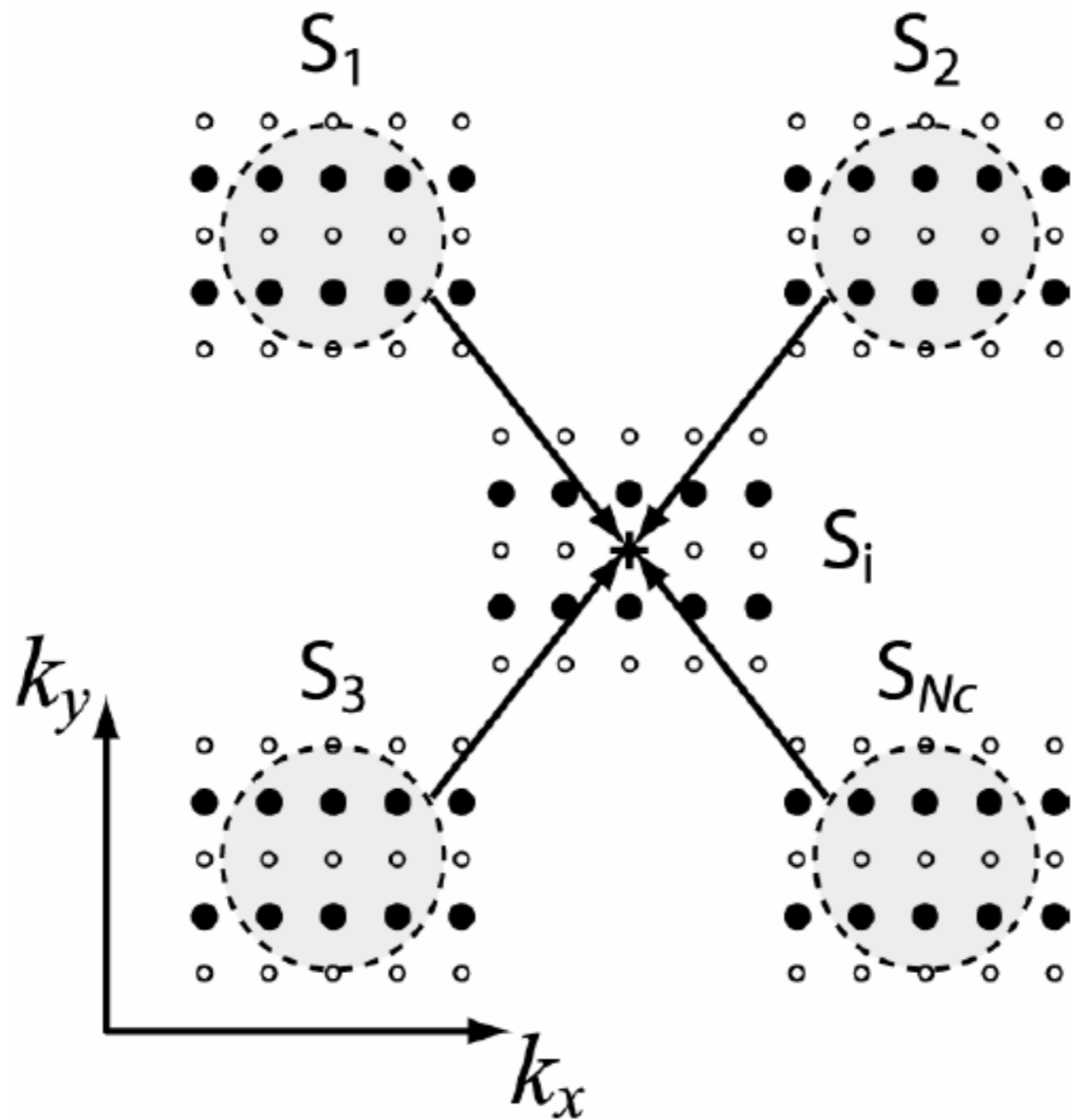

Auto-Calibration Parallel Imaging

coil = 1

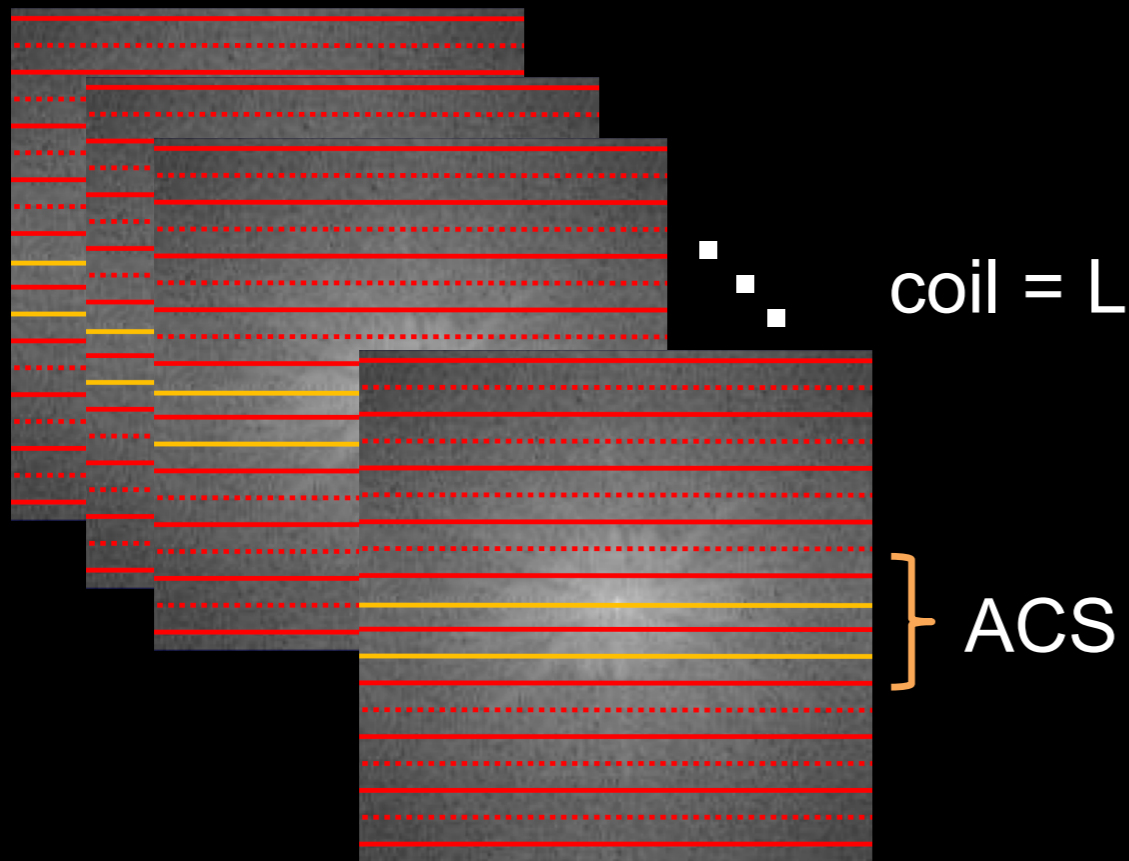

ACS (Auto-Calibration Signal) lines

$$\sum_{l=1}^L S_l^{ACS}(k_y - m\Delta k_y) = \sum_{l=1}^L n(l, m) S_l(k_y)$$

GRAPPA formula to reconstruct signal in one channel

$$S_j(k_y - m\Delta k_y) = \sum_{l=1}^L \sum_{b=0}^{N_b-1} n(j, b, l, m) S_l(k_y - bA\Delta k_y)$$

A: Acceleration factor
 n(j,b,l,m): GRAPPA weights

GRAPPA Reconstruction

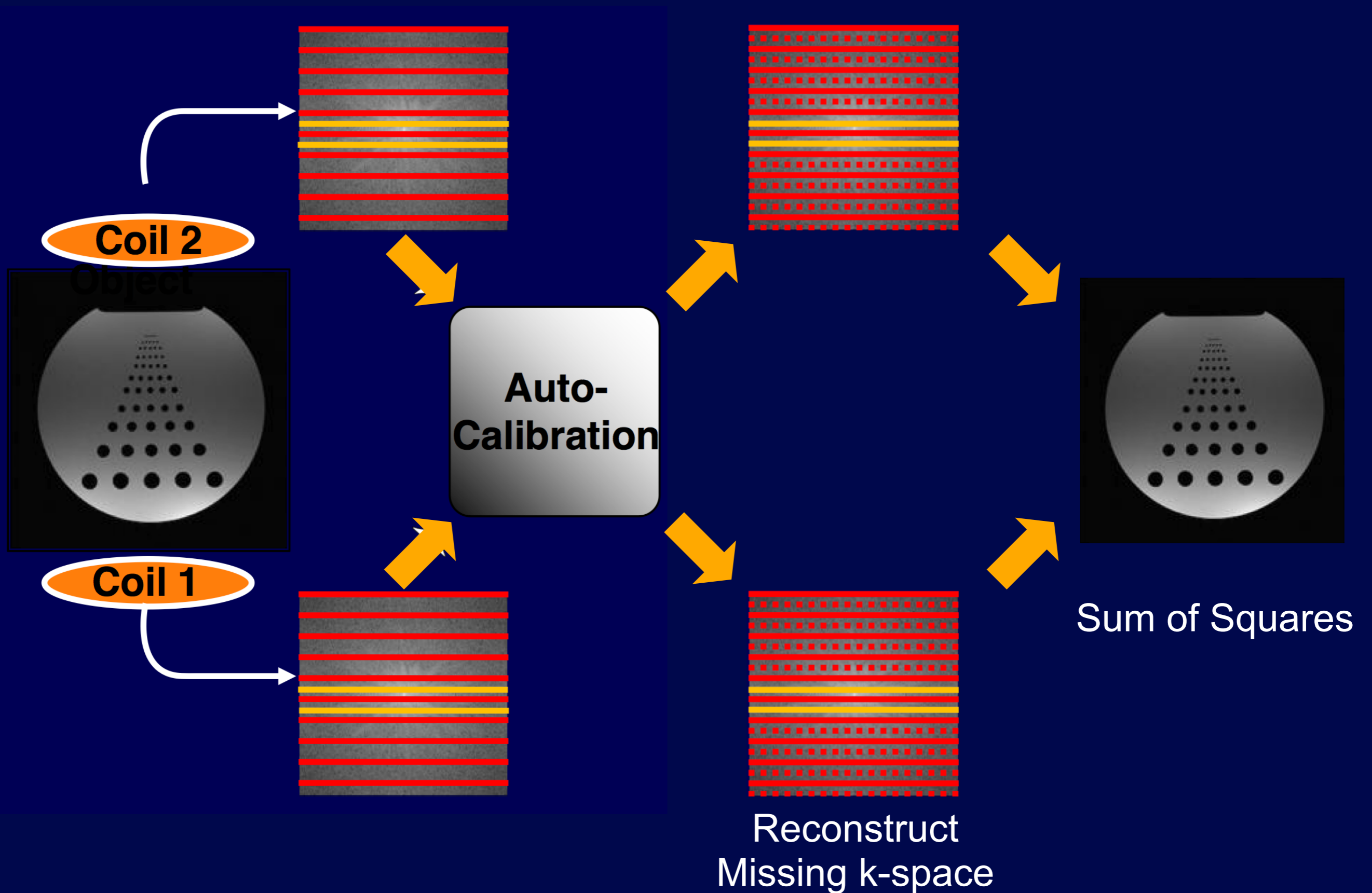

GRAPPA

- Compute GRAPPA weights from calibration region
- Compute missing k-space data using the GRAPPA weights
- Reconstruct individual coil images
- Combine coil images

Considerations of GRAPPA

- Calibration region size
- GRAPPA kernel size
- Sample geometry dependence

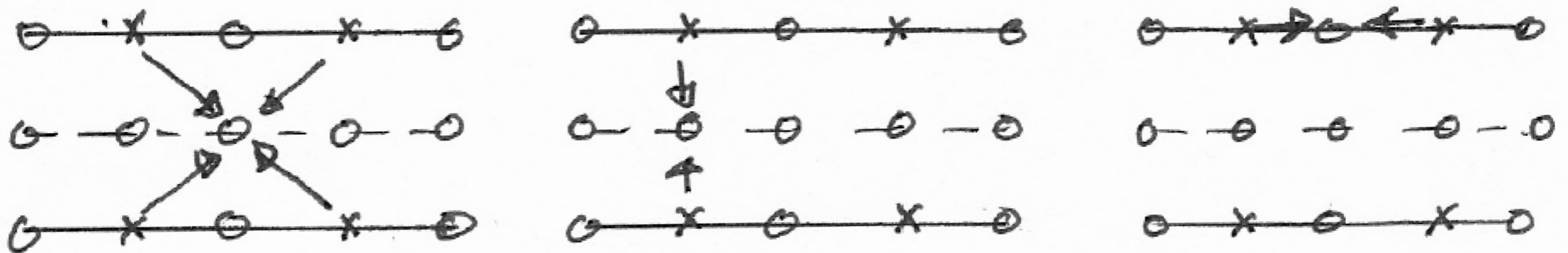

GRAPPA

- Compute GRAPPA weights from calibration region
- Compute missing k-space data using the GRAPPA weights
- Reconstruct individual coil images
- Combine coil images

Summary

- Parallel imaging utilizes coil sensitivities to increase the speed of MRI
- Cases for parallel imaging
 - Higher patient throughput,
 - Real-time imaging/Interventional imaging
 - Motion suppression
- Cases against parallel imaging
 - SNR starving applications

Summary

- Many approaches:
 - Image domain - SENSE
 - k-space domain - SMASH, GRAPPA
 - Hybrid - ARC

- We will focus on two:
 - SENSE: optimal if you know coil sensitivities
 - GRAPPA: autocalibrating / robust

Further Reading

- Multi-coil Reconstruction
 - <http://onlinelibrary.wiley.com/doi/10.1002/mrm.1910160203/abstract>
- SENSE
 - <http://www.ncbi.nlm.nih.gov/pubmed/10542355>
- SMASH
 - <http://www.ncbi.nlm.nih.gov/pubmed/9324327>
- Parallel Imaging Overview
 - <http://www.ncbi.nlm.nih.gov/pubmed/17374908>

Thanks!

- Next time
 - Compressed Sensing

Kyung Sung, PhD

ksung@mednet.ucla.edu

<https://mrrl.ucla.edu/sunqlab/>