

Image Reconstruction

Parallel Imaging

M229 Advanced Topics in MRI

Kyung Sung, Ph.D.

5/16/2024

Fourier Transform Symmetry

$$F(f) = \int_{-\infty}^{\infty} f_e(x) \cos(2\pi x f) dx - j \int_{-\infty}^{\infty} f_o(x) \sin(2\pi x f) dx$$

$$F(f) = F_e(f) + F_o(f)$$

real & even function?

real & odd function?

even function?

odd function?

Today's Topics

- Multicoil reconstruction
- Parallel imaging
 - Image domain methods:
 - SENSE
 - k-space domain methods:
 - SMASH
 - GRAPPA

Multi-coil Arrays

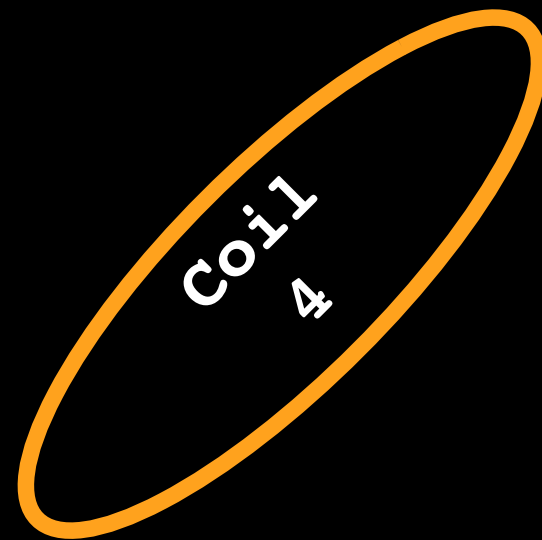
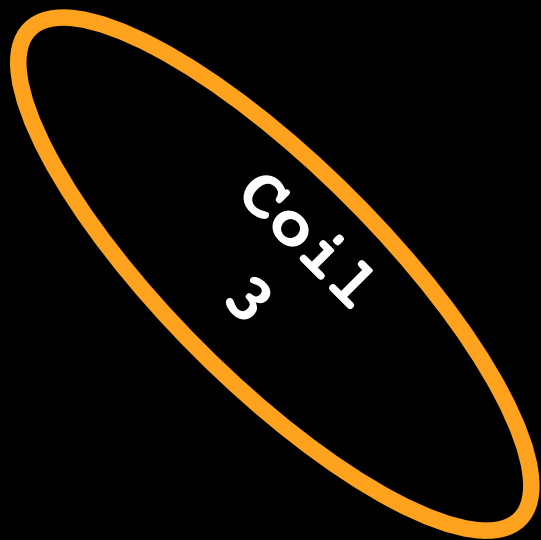
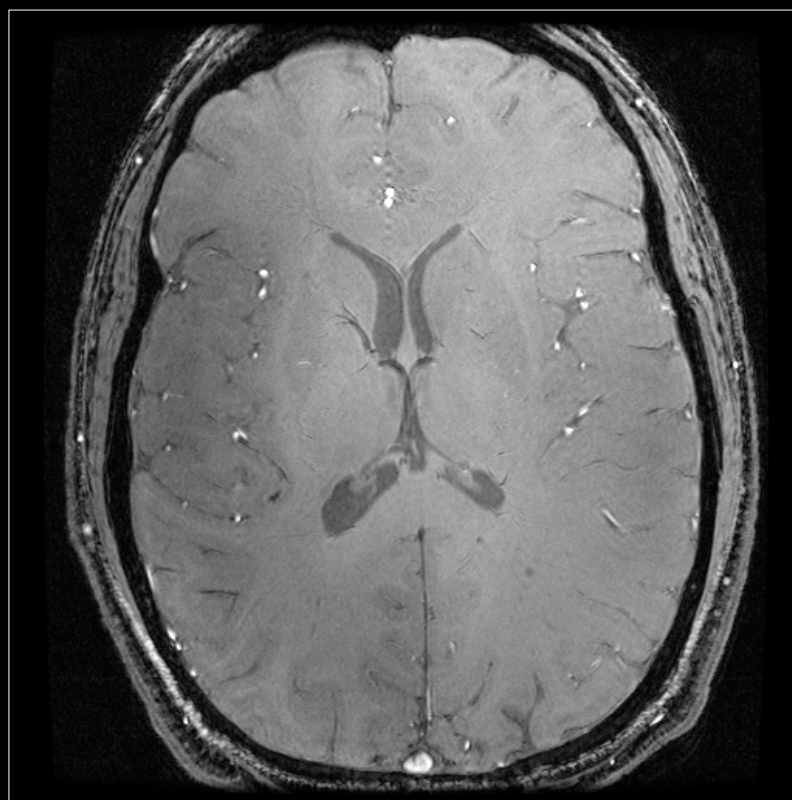
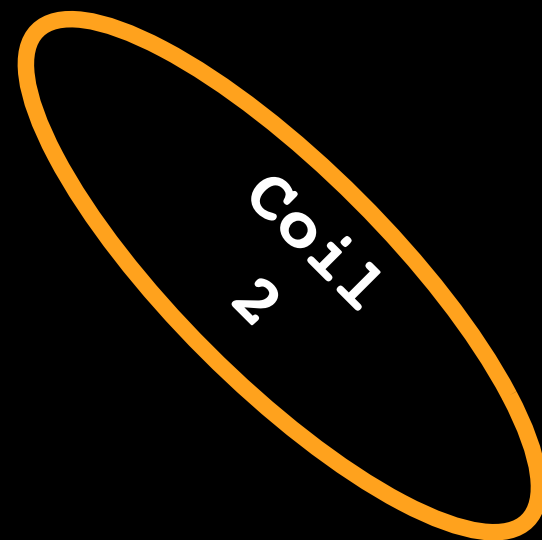
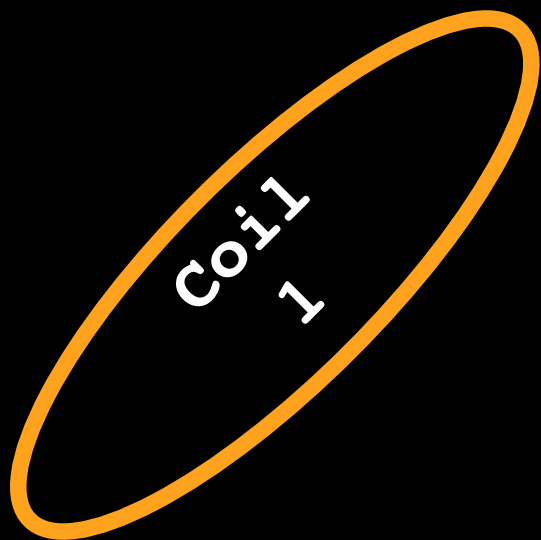

Multi-coil Sensitivity

$$\| \vec{B}(\vec{r}) \|$$

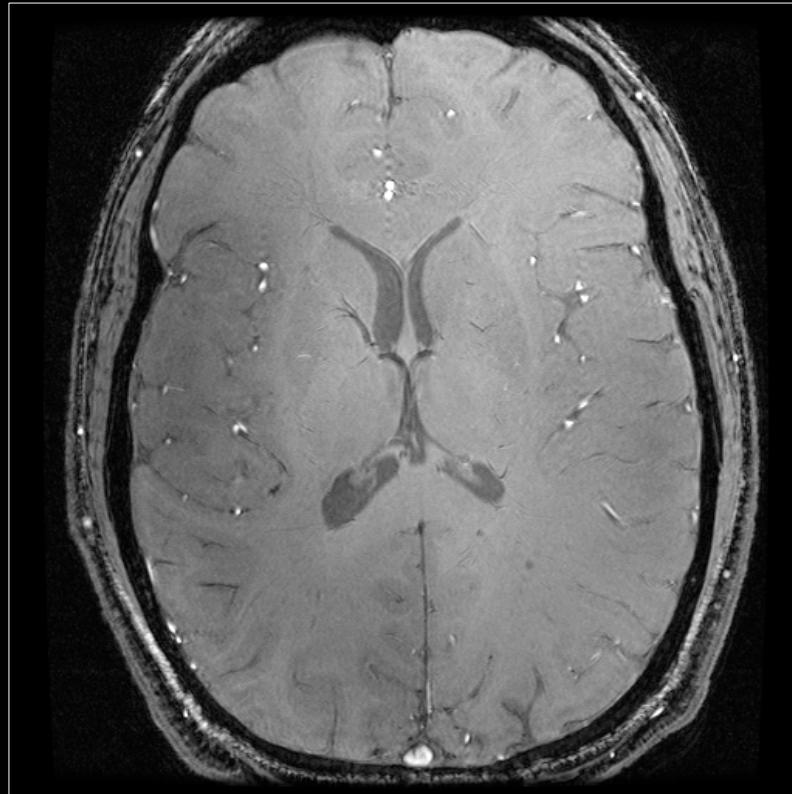

Multi-coil Reconstruction

- Each coil has a complete image of whole FOV and an amplitude and phase sensitivity

$$C_l(\vec{x}) \quad l = 1, 2, \dots, L$$

- Coils are coupled, so noise is correlated

$$E[n_i n_j] = \Psi$$

- Received data from coil l :

$$m_l(\vec{x}) = C_l(\vec{x})m(\vec{x}) + n_l(\vec{x})$$

- Given $m_l(x)$, how do we reconstruct $m(x)$?

Multi-coil Images

$m_1(x)$

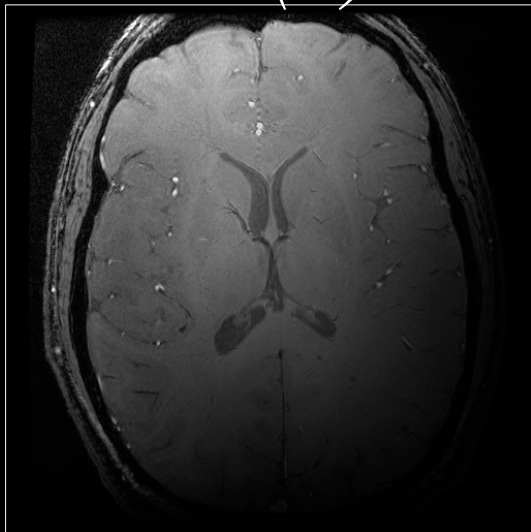

$m_2(x)$

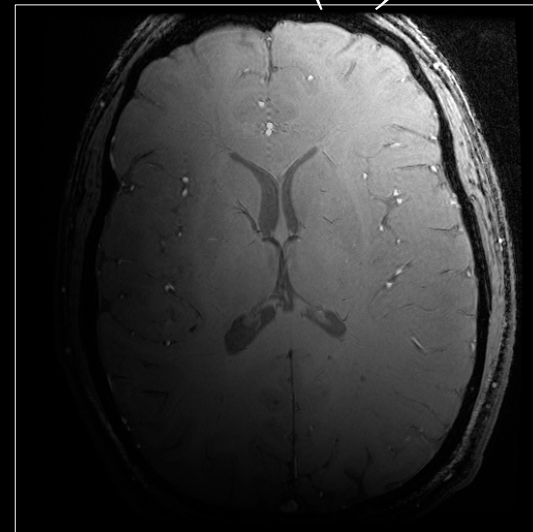

$m_s(x)$

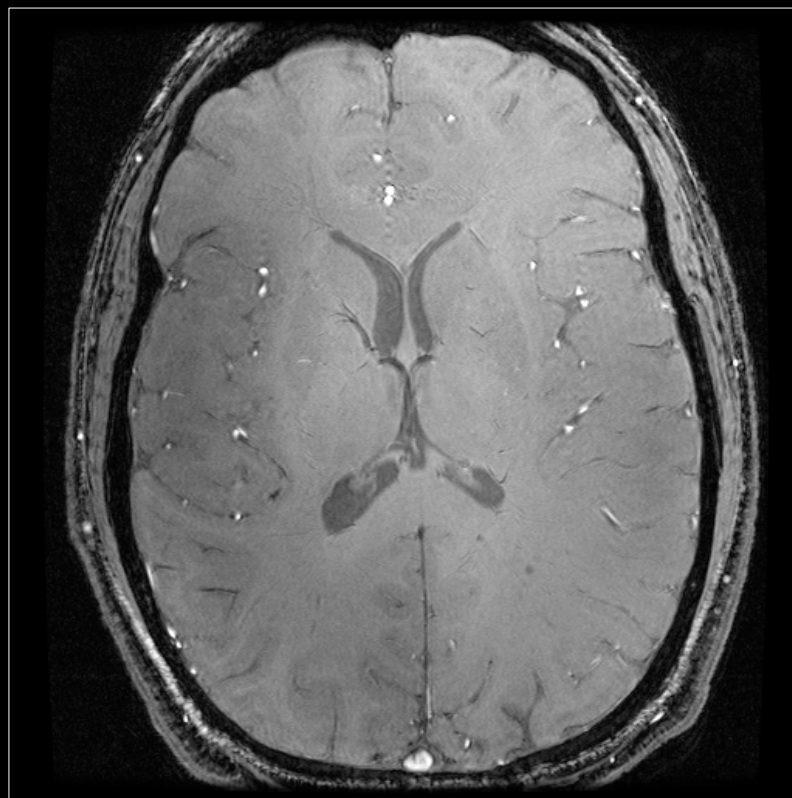

$m_3(x)$

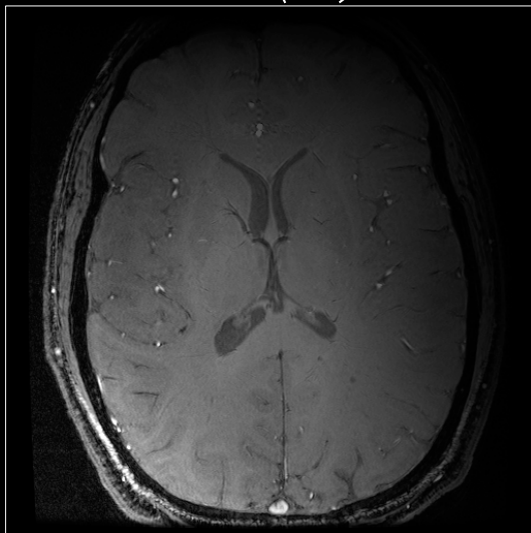

$m_4(x)$



Multi-coil Reconstruction

For a particular voxel \mathbf{x}

$$\begin{pmatrix} m_1(\vec{x}) \\ m_2(\vec{x}) \\ \vdots \\ m_L(\vec{x}) \end{pmatrix} = \begin{pmatrix} C_1(\vec{x}) \\ C_2(\vec{x}) \\ \vdots \\ C_L(\vec{x}) \end{pmatrix} m(\vec{x}) + \begin{pmatrix} n_1(\vec{x}) \\ n_2(\vec{x}) \\ \vdots \\ n_L(\vec{x}) \end{pmatrix}$$

OR

$$\begin{array}{ccccc} m_s(\vec{x}) & = & C & m(\vec{x}) & + & n \\ \text{L} \times \text{1} & & \text{L} \times \text{1} & & & \text{L} \times \text{1} \end{array}$$

Minimum Variance Estimate

$$\hat{m}(\vec{x}) = \underbrace{(C^* \Psi^{-1} C)^{-1}}_{1 \times 1} \underbrace{C^* \Psi^{-1}}_{1 \times L} \underbrace{m_s(\vec{x})}_{L \times 1}$$

Covariance (variance)

$$COV(\hat{m}(\vec{x})) = C^* \Psi^{-1} C$$

What if Ψ is $\sigma^2 I$?

$$\hat{m}(\vec{x}) = \underbrace{(C^* C)^{-1}}_{\text{Intensity Correction}} \underbrace{C^*}_{\text{Phase Correction}} m_s(\vec{x})$$

Intensity Correction Phase Correction

Approximate Solution

- Often we don't know $C_l(x)$, but

$$m_l(\vec{x}) = C_l(\vec{x})m(\vec{x})$$

- Approximate solution:

$$\hat{m}_{SS}(\vec{x}) = \sqrt{\sum_l m_l^*(\vec{x})m_l(\vec{x})}$$

- For SNR > 20, within 10% of optimal solution

Accelerate Imaging with Array Coils

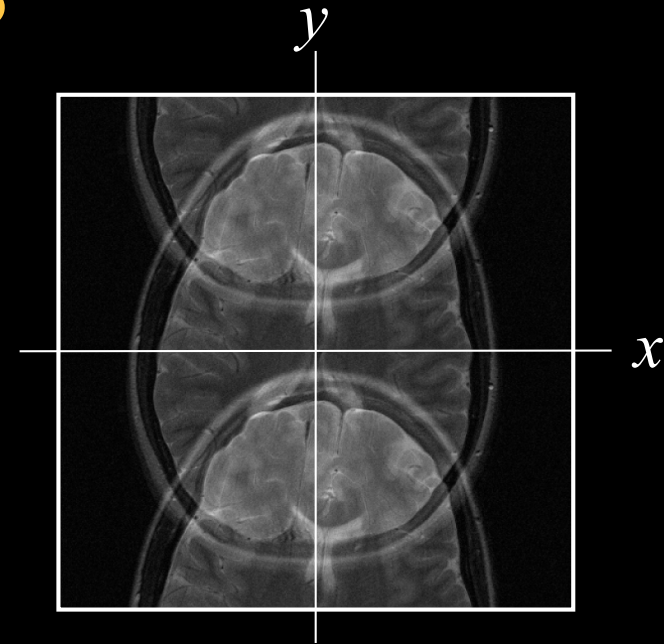
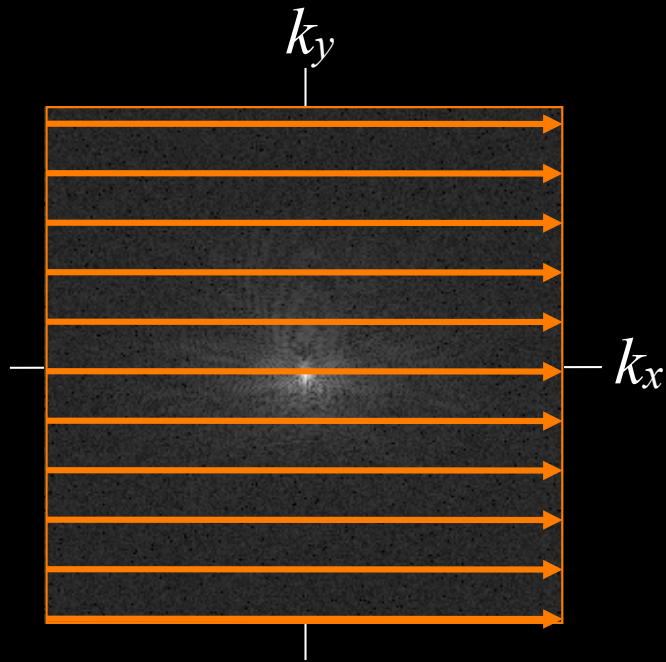

Accelerate Imaging with Array Coils

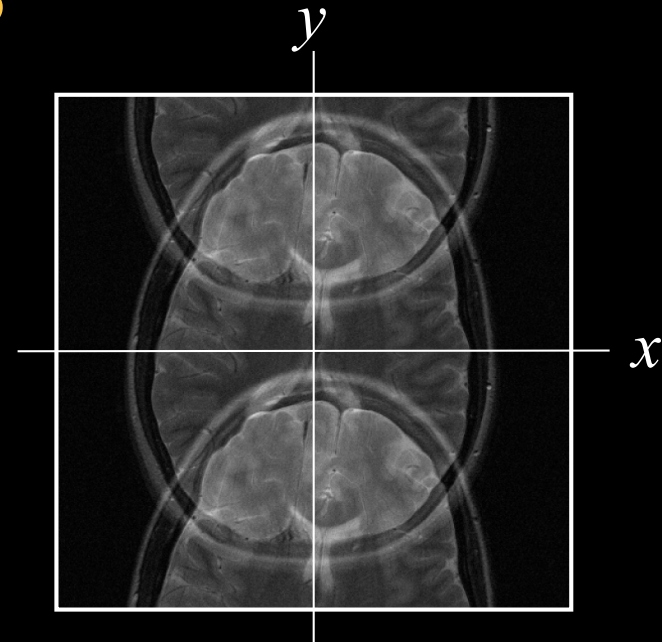
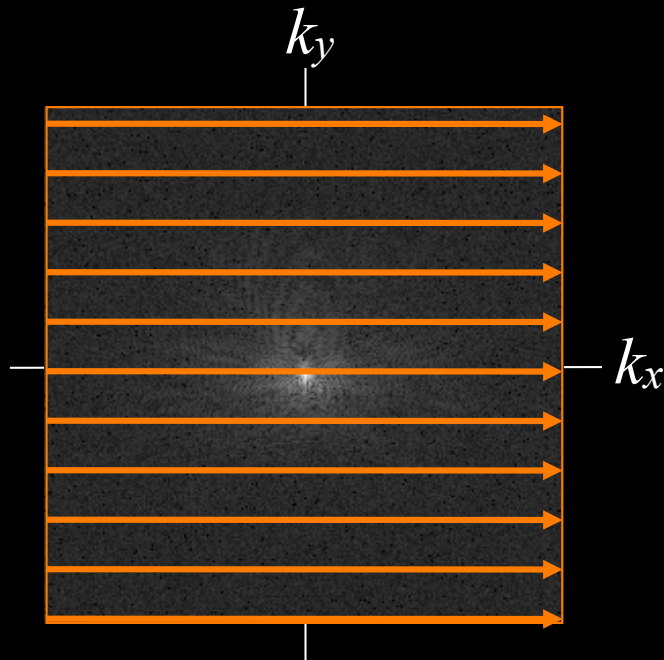

- Parallel Imaging
 - Coil elements provide some localization
 - Undersample in k-space, producing aliasing
 - Sort out in reconstruction

Parallel Imaging

- Many approaches:
 - Image domain - SENSE
 - k-space domain - SMASH, GRAPPA
 - Hybrid - ARC

- We will focus on two:
 - SENSE: optimal if you know coil sensitivities
 - GRAPPA: autocalibrating / robust

Parallel Imaging (SENSE)

Cartesian SENSE

$$m_1(\vec{x}_1) = C_1(\vec{x}_1)m(\vec{x}_1) + C_1(\vec{x}_2)m(\vec{x}_2)$$

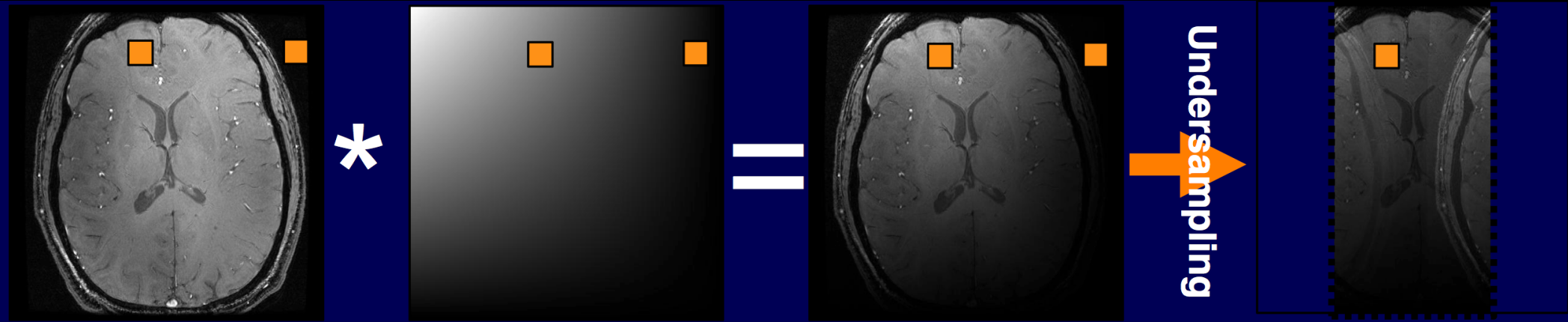

$$m_2(\vec{x}_1) = C_2(\vec{x}_1)m(\vec{x}_1) + C_2(\vec{x}_2)m(\vec{x}_2)$$

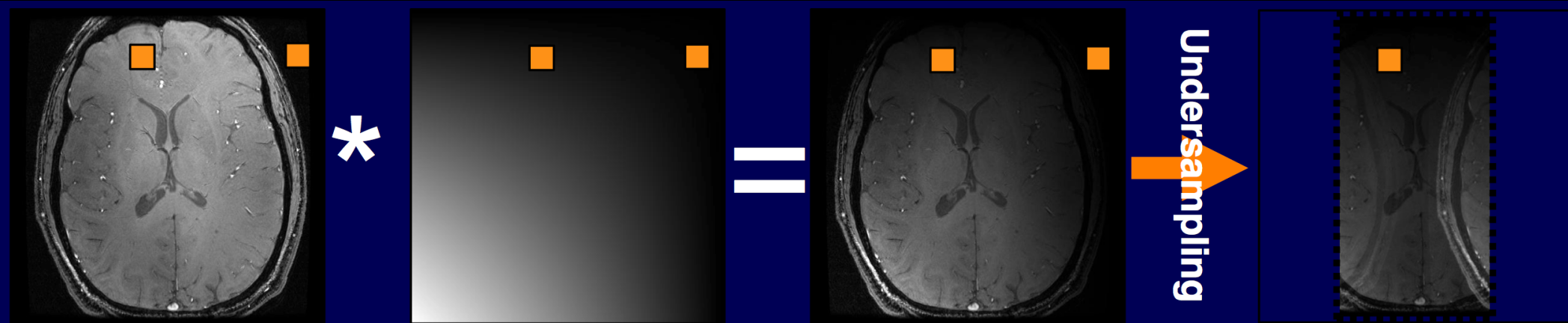

$$\begin{pmatrix} m_1(\vec{x}_1) \\ m_2(\vec{x}_1) \\ \vdots \\ m_L(\vec{x}_1) \end{pmatrix} = \begin{pmatrix} C_1(\vec{x}_1) & C_1(\vec{x}_2) \\ C_2(\vec{x}_1) & C_2(\vec{x}_2) \\ \vdots & \vdots \\ C_L(\vec{x}_1) & C_L(\vec{x}_2) \end{pmatrix} \begin{pmatrix} m(\vec{x}_1) \\ m(\vec{x}_2) \end{pmatrix} + \begin{pmatrix} n_1(\vec{x}_1) \\ n_2(\vec{x}_1) \\ \vdots \\ n_L(\vec{x}_1) \end{pmatrix}$$

Aliased
Images

Sensitivity at
Source Voxels

Source
Voxels

OR

$$\begin{matrix} & & 2 \times 1 \\ m_s = & C & m + n \\ L \times 1 & L \times 2 & L \times 1 \end{matrix}$$

$$\hat{m}(\vec{x}) = \underbrace{(C^* \Psi^{-1} C)^{-1}}_{2 \times 2} \underbrace{C^* \Psi^{-1}}_{2 \times L} \underbrace{m_s(\vec{x})}_{L \times 1}$$

L aliased reconstruction resolves 2 image pixels

For an N x N image, we solve (N/2 x N)
2 x 2 inverse systems

For an acceleration factor R, we solve (N/R x N)
R x R inverse systems

SENSE Reconstruction

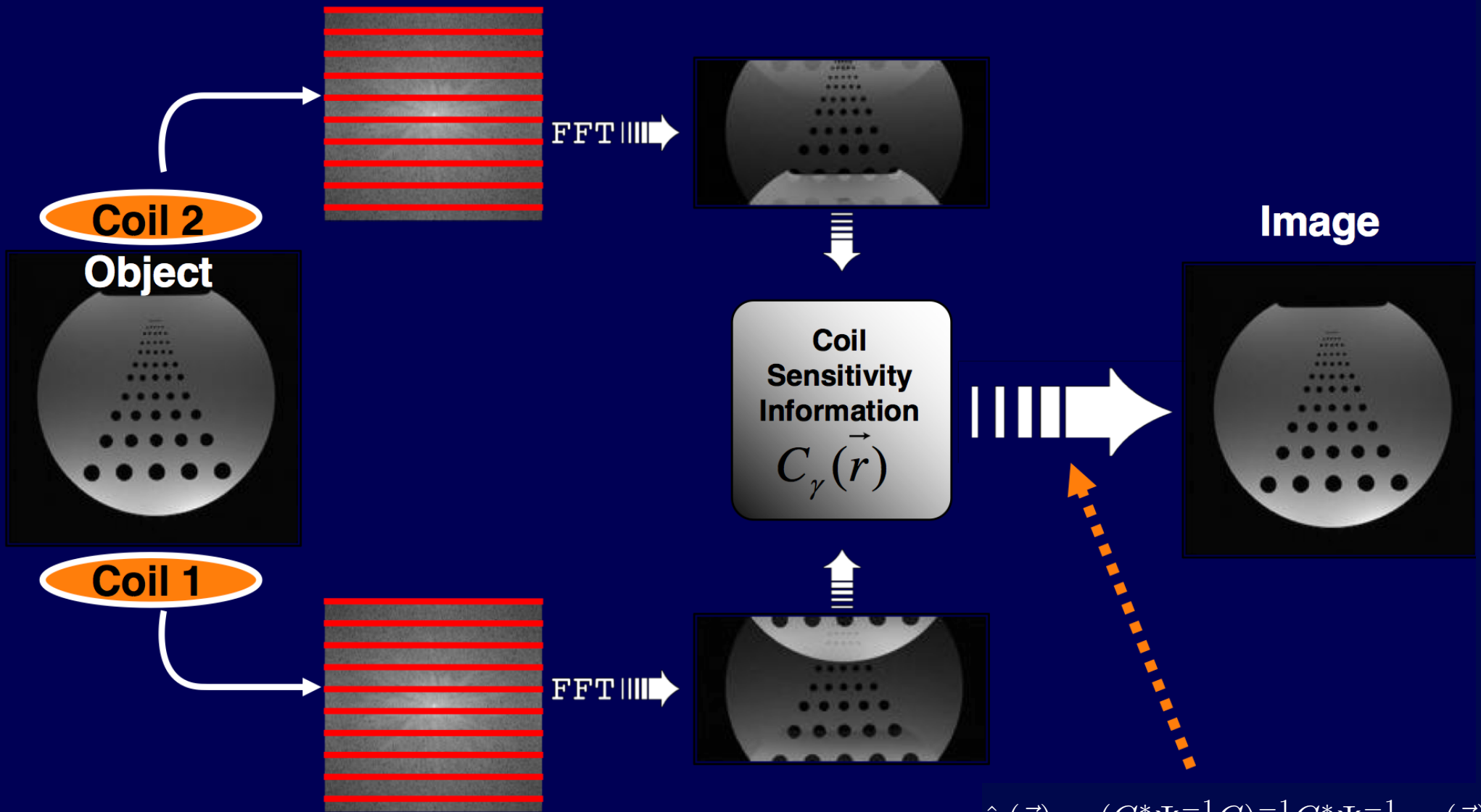

$$\hat{m}(\vec{x}) = (C^* \Psi^{-1} C)^{-1} C^* \Psi^{-1} m_s(\vec{x})$$

Unwrap fold over in image space

SNR Cost

- How large can R be?
- Two SNR loss mechanisms
 - Reduced scan time
 - Condition of the SENSE decomposition
- SNR Loss

$$SNR_{SENSE} = \frac{SNR}{g\sqrt{R}}$$

Geometry Reduced
Factor Scan Time

Geometry Factor

- Covariance for a fully sampled image (variance of one voxel):

$$\chi_F = \frac{1}{n_F} (C_F^* \Psi^{-1} C_F)^{-1}$$

- Covariance for a reduced encoded image:

$$\chi_R = \frac{1}{n_R} (C_R^* \Psi^{-1} C_R)^{-1}$$



Geometry Factor

- g-factor is critical since it depends on:
 - Acceleration
 - Spatial position
 - Aliasing direction
 - Coil geometry
- Minimizing g-factor drives system design
- Sense coils are different from traditional array coils



Parallel Imaging Tradeoffs

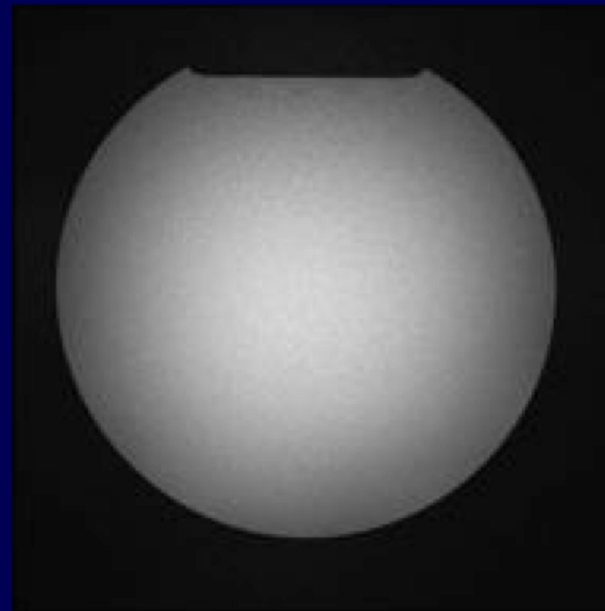

PAT x 2

f_p = acceleration
factor

g = coil geometry
factor

PAT x 3

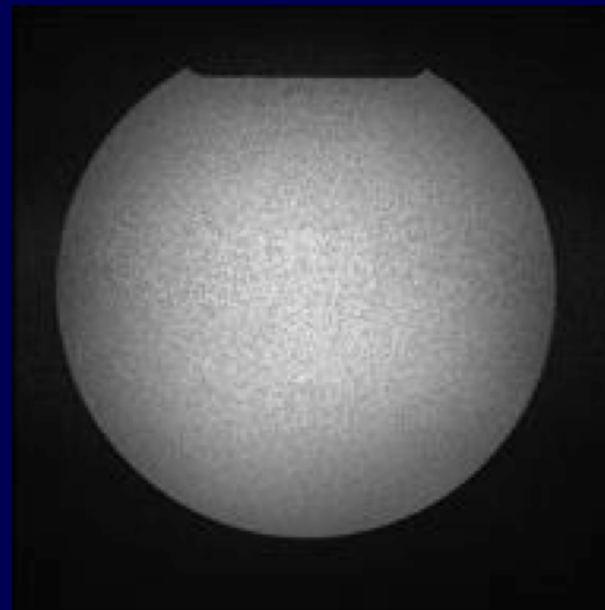
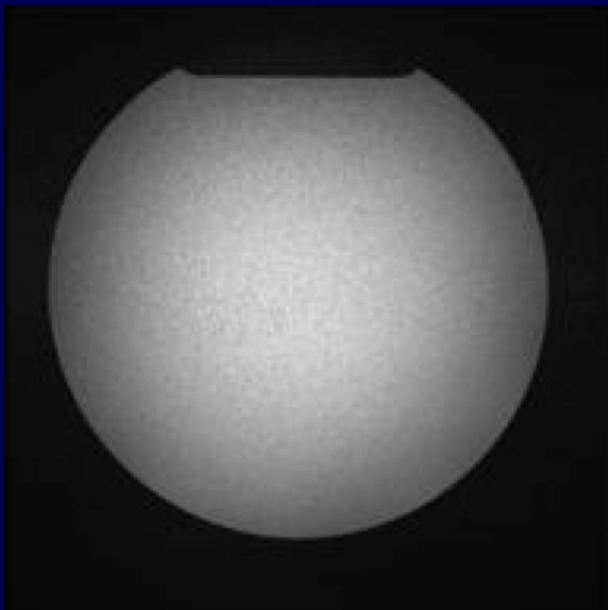

PAT x 4

1/g-factor Map for R=4

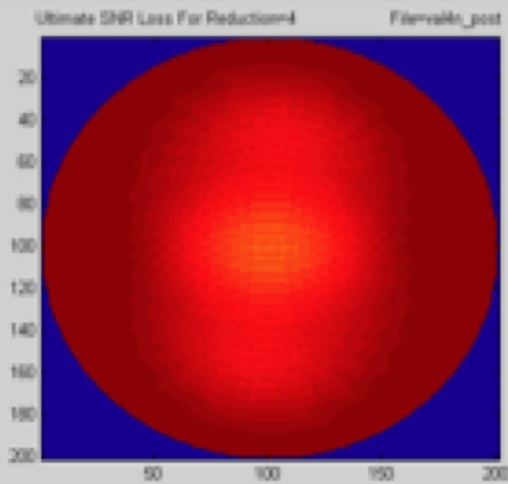

∞ elements

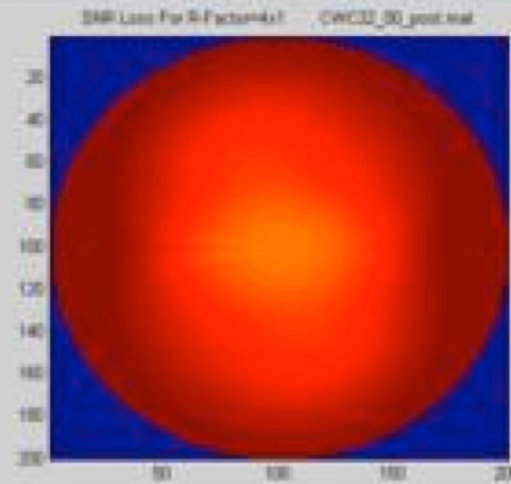

32 elements

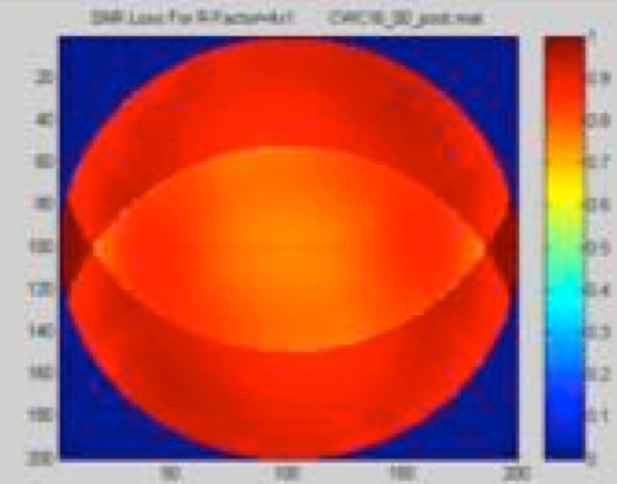

16 elements

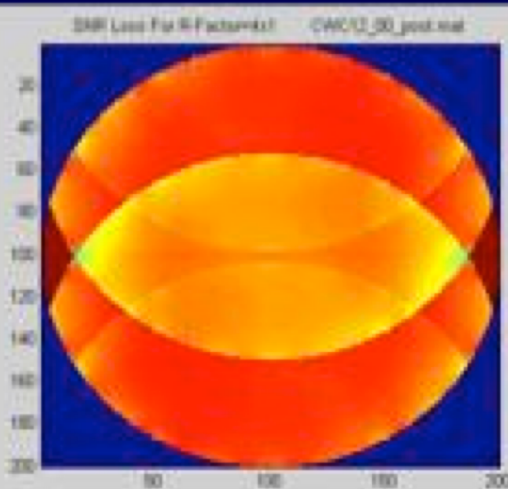

12 elements

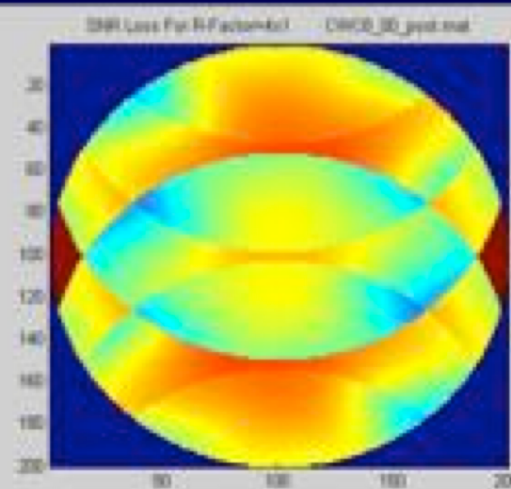

8 elements

Relative
SNR
Scale

g-factor and its impact on images

Rate 1

2

2.4

3

4

g-map



SENSE

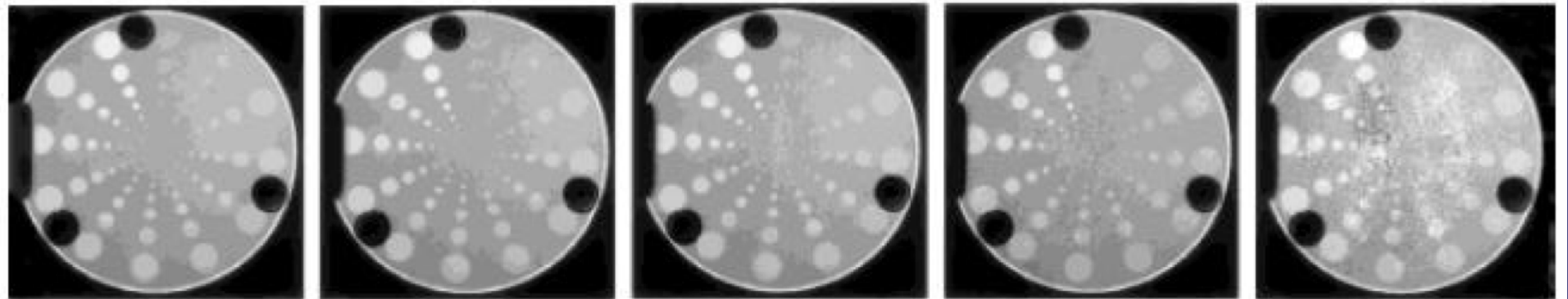

aliased

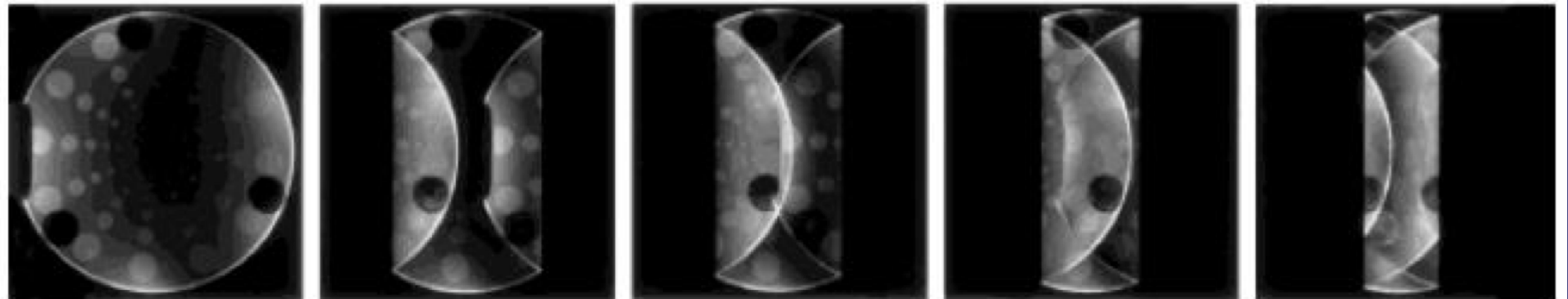

Dependence on Coil Sensitivity

- Images reconstructed using coil sensitivity maps with different order P of polynomial fitting

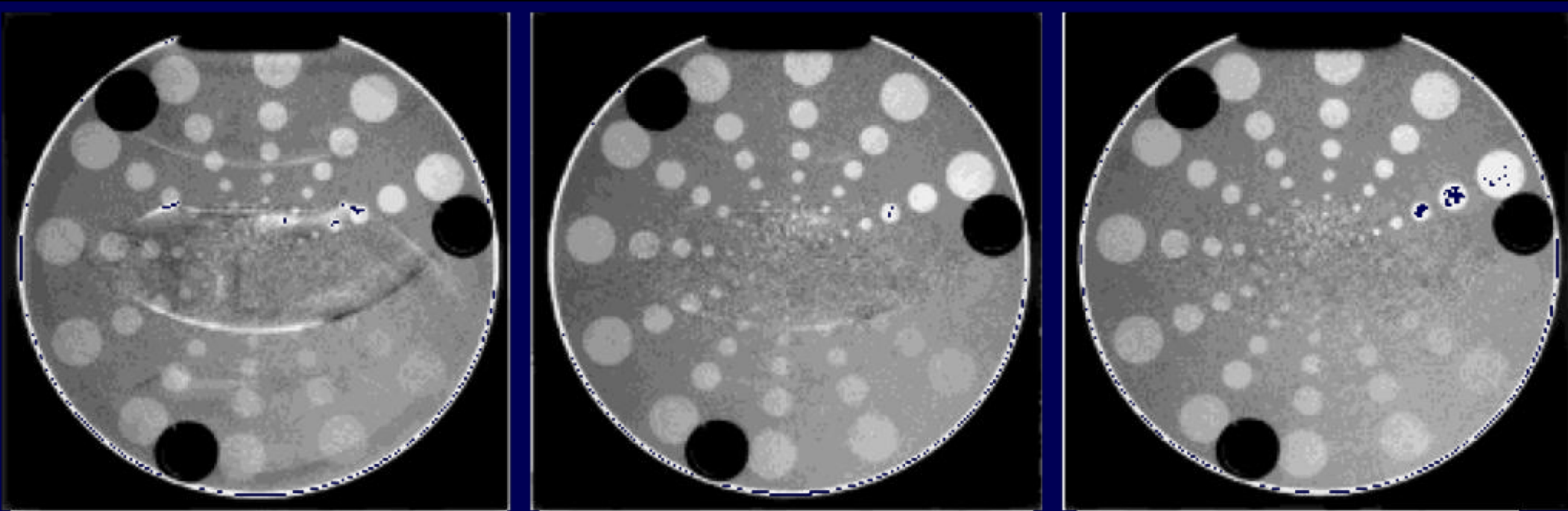

$P=0$

$P=1$

$P=2$

Parallel Imaging (GRAPPA)

GRAPPA

- Coil sensitivities are
 - Smooth in image space
 - Local in k-space

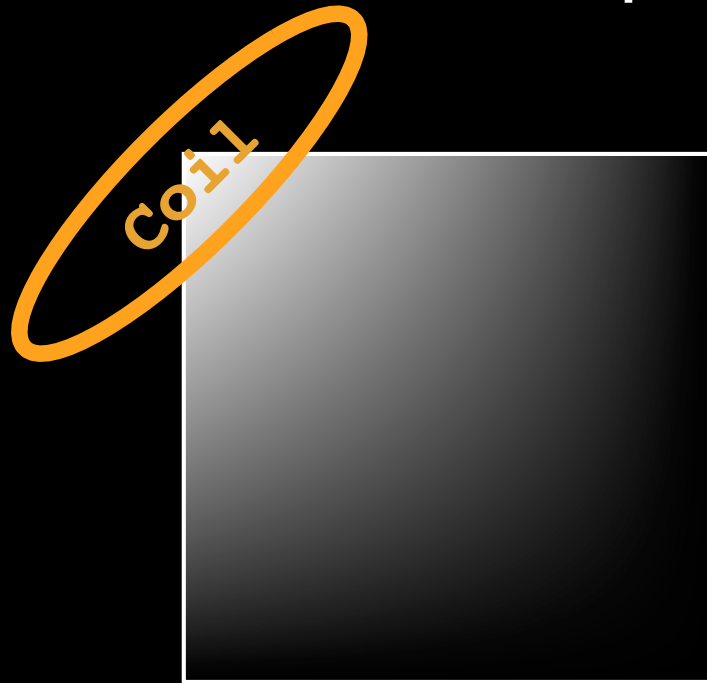

$$m(\vec{x})C_j(\vec{x})$$

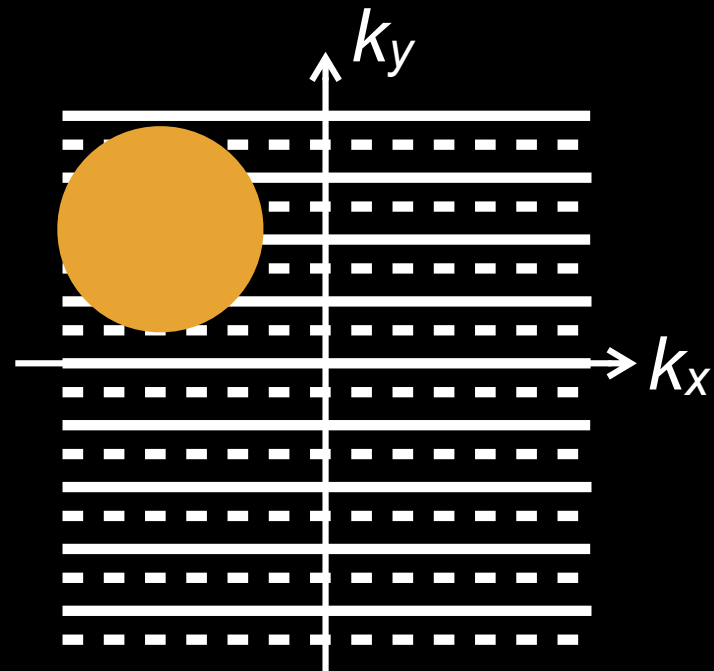

$$M(\vec{k}) * C_j(\vec{k})$$

GRAPPA

- Missing information is implicitly contained by adjacent data

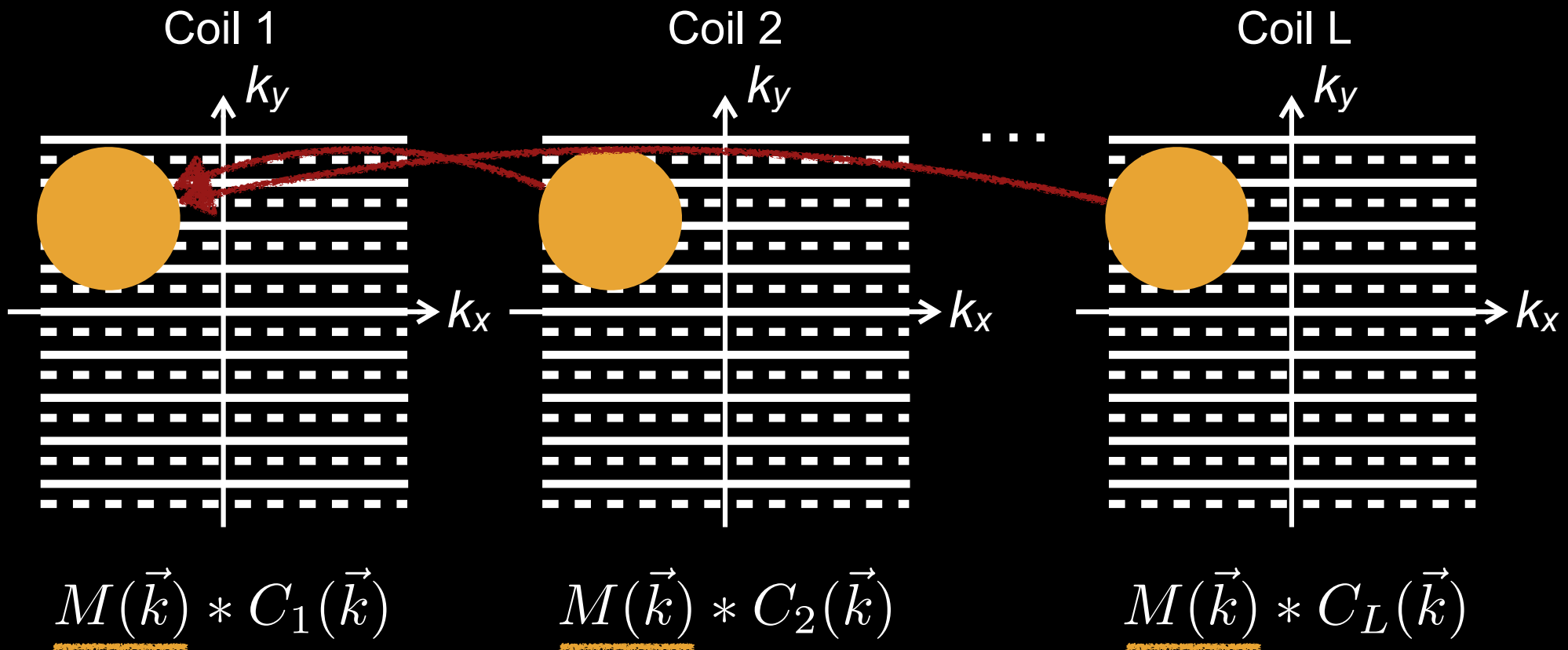

GRAPPA Reconstruction

- How do we find missing data from these samples?

$$\hat{m}_k(k_x, k_y) = \sum_{i,j,k} a_{i,j,k} \cdot m_k(k_x + i\Delta k_x, k_y + j\Delta k_y)$$

missing data
for each coil

weights

neighborhood data
for each coil

Auto-Calibration

$$\hat{m}_k(k_x, k_y) = \sum_{i,j,k} a_{i,j,k} \cdot m_k(k_x + i\Delta k_x, k_y + j\Delta k_y)$$

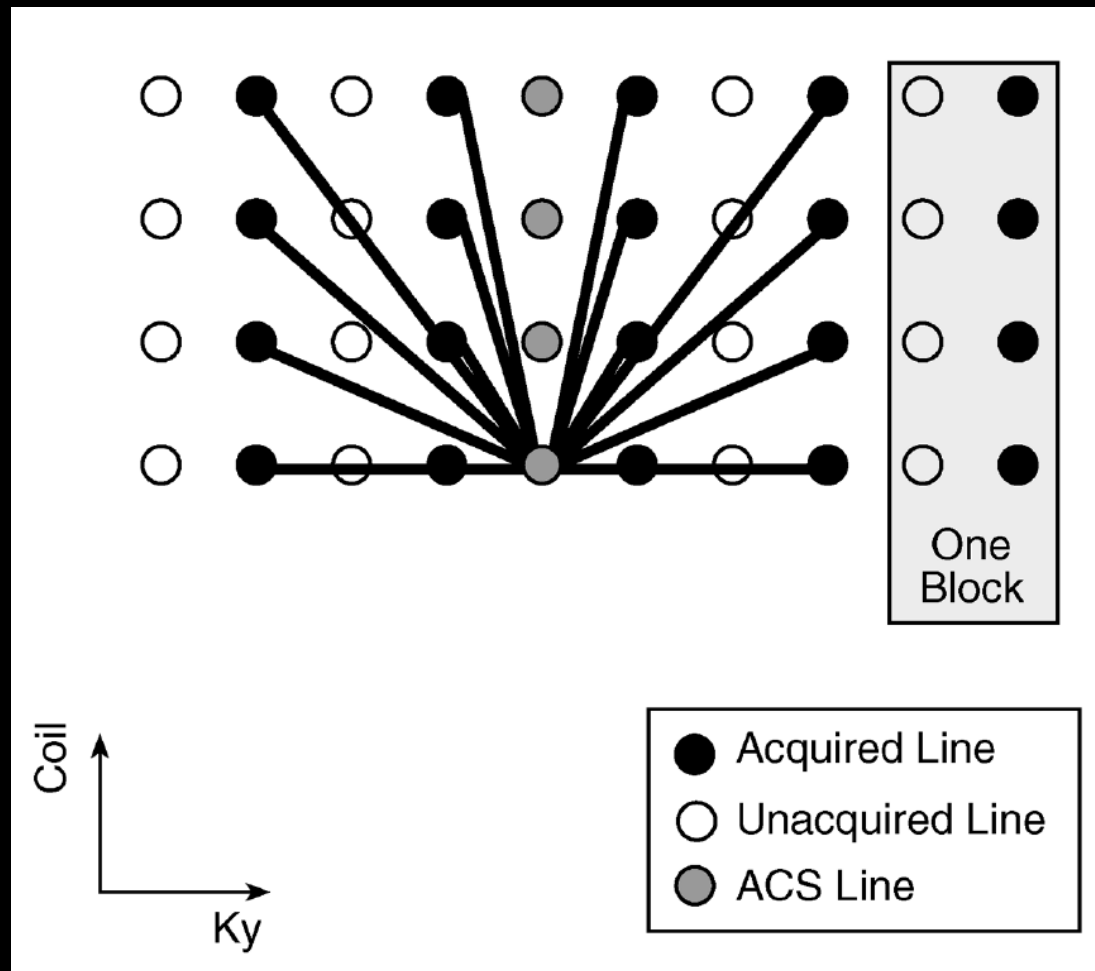

Auto-Calibration

- Assume there is a fully sampled region
- We have samples of what the GRAPPA synthesis equations should produce

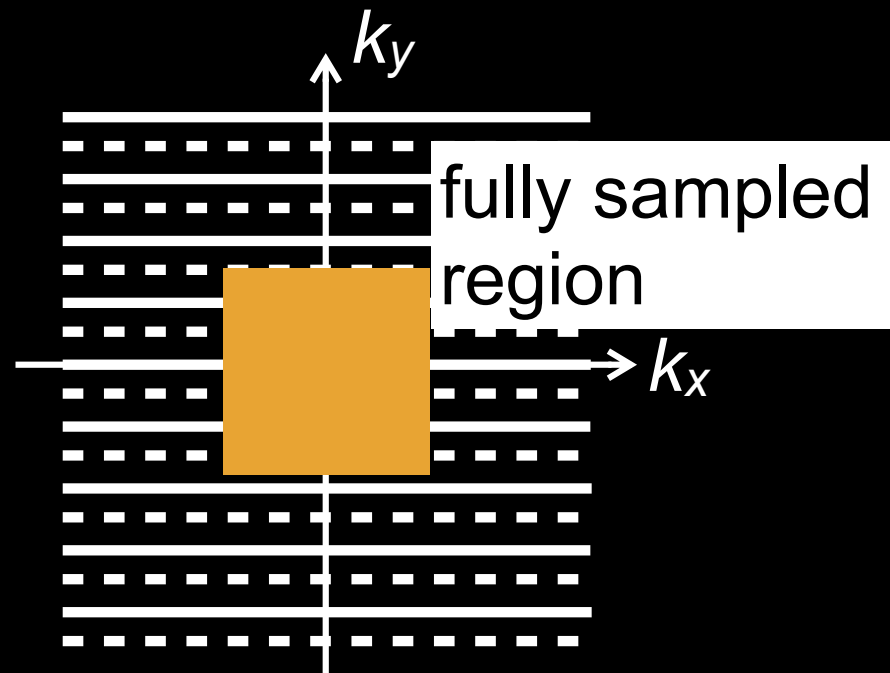

- Invert this to solve for GRAPPA weights

Auto-Calibration

- Calibration area has to be larger than the GRAPPA kernel
- Each shift of kernel gives another equation

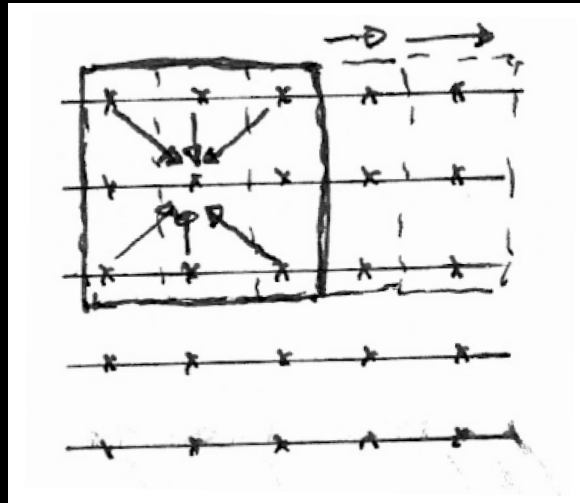

- Here, 3x3 kernel, 5x5 calibration area gives 9 equations

Auto-Calibration

$$\hat{m}_k(k_x, k_y) = \sum_{i,j,k} a_{i,j,k} \cdot m_k(k_x + i\Delta k_x, k_y + j\Delta k_y)$$

- Write as a matrix equation

GRAPPA

Coefficients

$$M_{k,c} = M_A \cdot a_k$$

Calibration Neighborhood

Data Data

- GRAPPA weights are:

$$a_k = (M_A^* M_A + \lambda I)^{-1} M_A^* M_{k,c}$$

GRAPPA - Synthesis

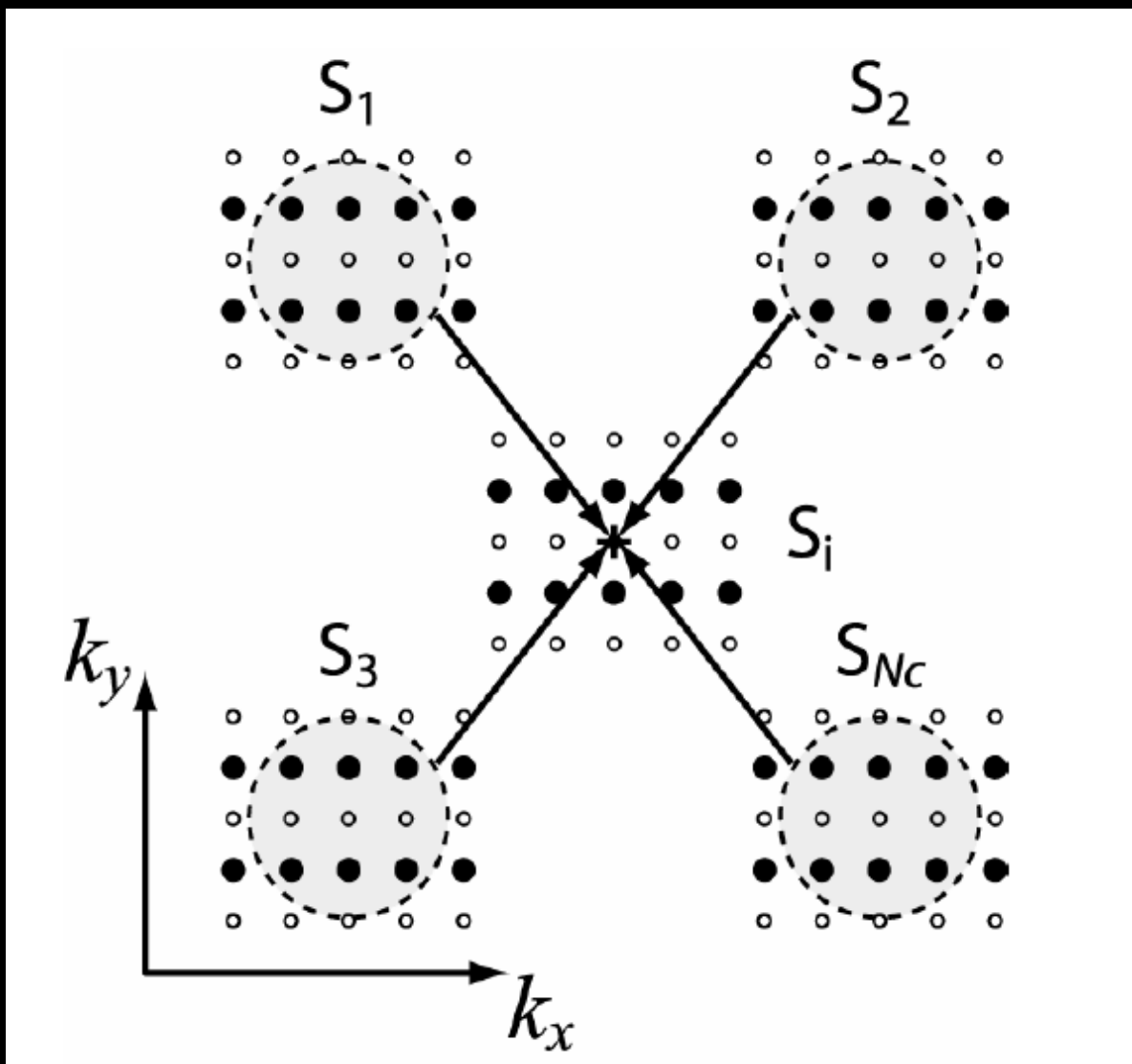

Auto-Calibration Parallel Imaging

coil = 1

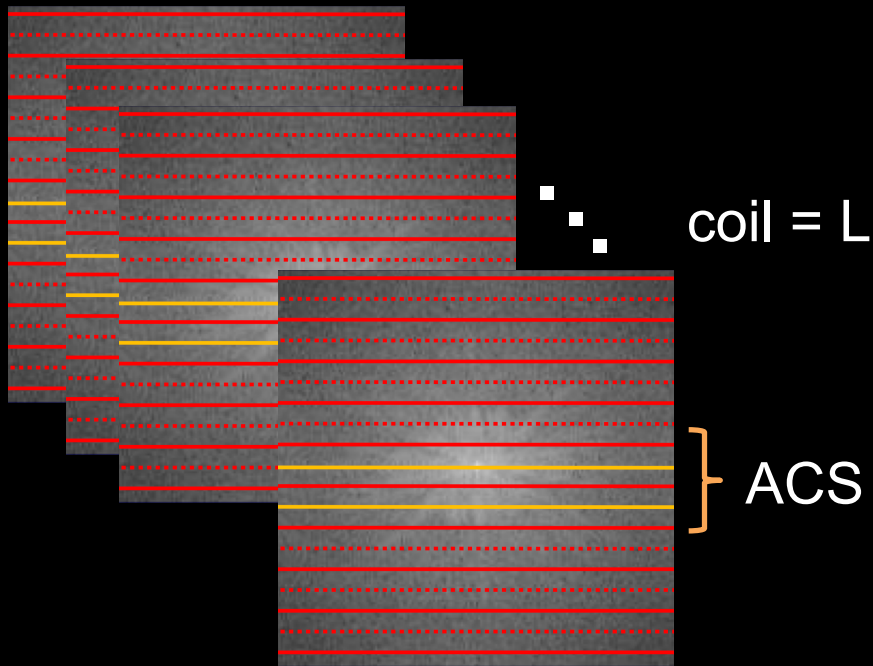

coil = L

ACS

ACS (Auto-Calibration Signal) lines

$$\sum_{l=1}^L S_l^{ACS}(k_y - m\Delta k_y) = \sum_{l=1}^L n(l, m) S_l(k_y)$$

GRAPPA formula to reconstruct signal in one channel

$$S_j(k_y - m\Delta k_y) = \sum_{l=1}^L \sum_{b=0}^{N_b-1} n(j, b, l, m) S_l(k_y - bA\Delta k_y)$$

A: Acceleration factor
 $n(j, b, l, m)$: GRAPPA weights

GRAPPA Reconstruction

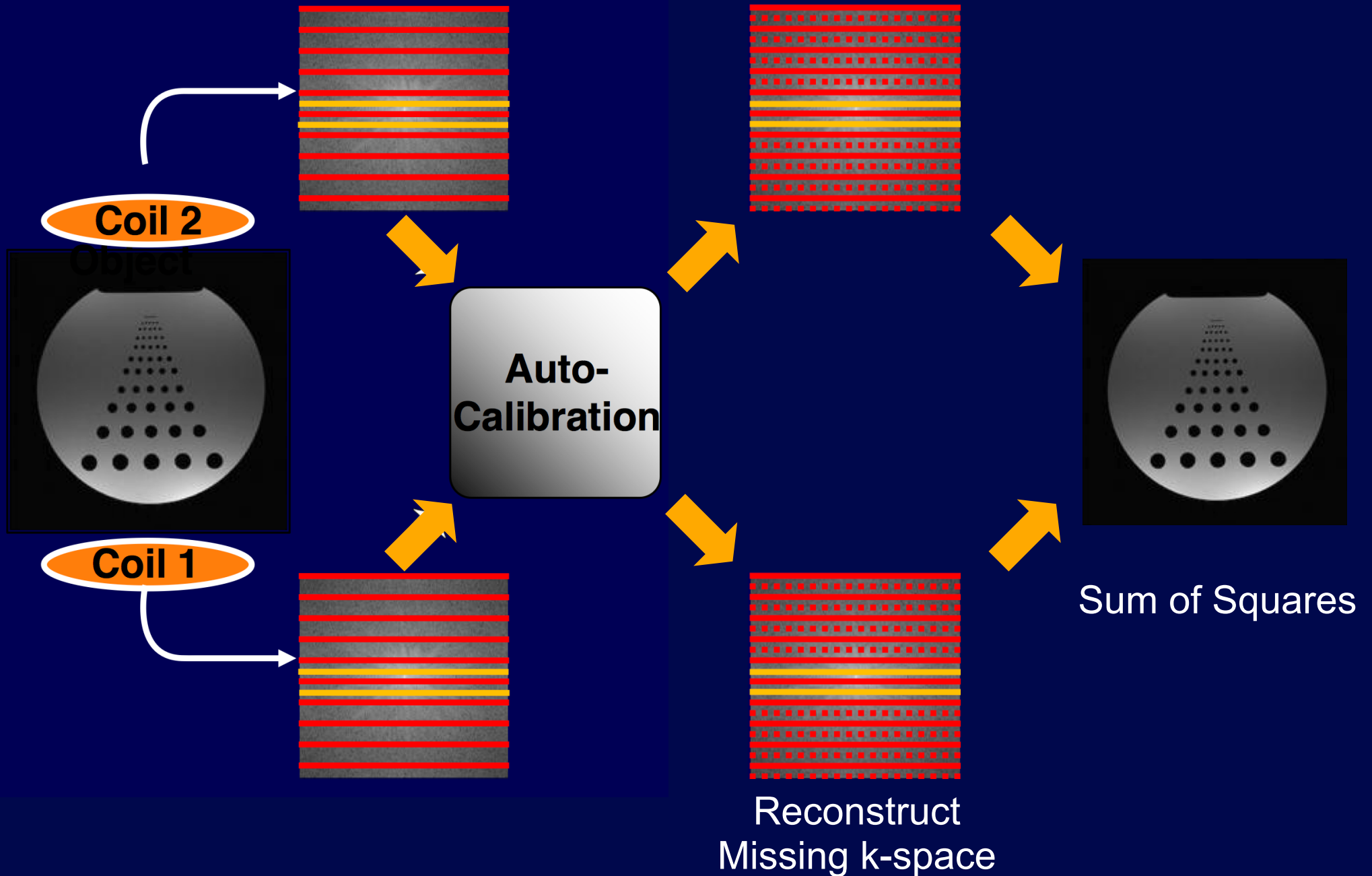

GRAPPA

- Compute GRAPPA weights from calibration region
- Compute missing k-space data using the GRAPPA weights
- Reconstruct individual coil images
- Combine coil images

Considerations of GRAPPA

- Calibration region size
- GRAPPA kernel size
- Sample geometry dependence

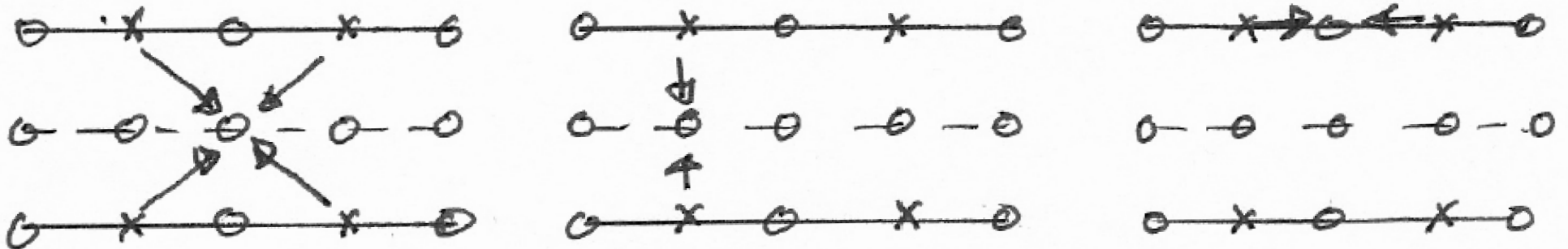

GRAPPA

- Compute GRAPPA weights from calibration region
- Compute missing k-space data using the GRAPPA weights
- Reconstruct individual coil images
- Combine coil images

Summary

- Parallel imaging utilizes coil sensitivities to increase the speed of MRI
- Cases for parallel imaging
 - Higher patient throughput,
 - Real-time imaging/Interventional imaging
 - Motion suppression
- Cases against parallel imaging
 - SNR starving applications

Summary

- Many approaches:
 - Image domain - SENSE
 - k-space domain - SMASH, GRAPPA
 - Hybrid - ARC

- We will focus on two:
 - SENSE: optimal if you know coil sensitivities
 - GRAPPA: autocalibrating / robust

Further Reading

- Multi-coil Reconstruction
 - <http://onlinelibrary.wiley.com/doi/10.1002/mrm.1910160203/abstract>
- SENSE
 - <http://www.ncbi.nlm.nih.gov/pubmed/10542355>
- SMASH
 - <http://www.ncbi.nlm.nih.gov/pubmed/9324327>
- Parallel Imaging Overview
 - <http://www.ncbi.nlm.nih.gov/pubmed/17374908>

Thanks!

Kyung Sung, PhD

ksung@mednet.ucla.edu

<https://mrrl.ucla.edu/sunglab/>